



**PHYSICS
HIGHER LEVEL
PAPER 1**

SPECIMEN PAPER

1 hour

INSTRUCTIONS TO CANDIDATES

- Do not open this examination paper until instructed to do so.
- Answer all the questions.
- For each question, choose the answer you consider to be the best and indicate your choice on the answer sheet provided.

1. An elephant has a life expectancy of 60 years. Which of the following gives the order of magnitude of this lifetime?

- A. 10^{11} s
- B. 10^9 s
- C. 10^7 s
- D. 10^5 s

2. The frequency f of waves of wavelength λ travelling on the surface of deep water is given by

$$f = \sqrt{\frac{g}{2\pi\lambda}}$$

where g is the acceleration of free fall.

Which of the following will yield a straight-line graph?

	y-axis	x-axis
A.	f^2	$\frac{1}{\lambda}$
B.	f^2	λ
C.	f	λ
D.	f	$\frac{1}{\lambda}$

3. The period T of oscillation of a mass m on a spring, having spring constant k is $T = 2\pi\sqrt{\frac{m}{k}}$.
The uncertainty in k is 11 % and the uncertainty in m is 5 %. The approximate uncertainty in T is
- A. 4%.
 - B. 6%.
 - C. 8%.
 - D. 16%.
4. An electric motor has an input power of 160 W. In raising a load, 120 W of power is dissipated. The best estimate for the efficiency of the motor is
- A. 25%.
 - B. 33%.
 - C. 57%.
 - D. 75%.

5. The variation with time of the vertical speed of a ball falling in air is shown below.

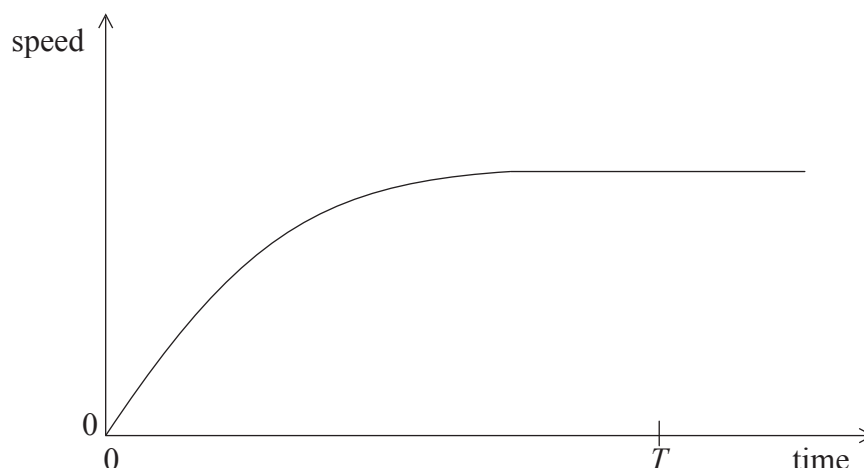

During the time from 0 to T , the ball gains kinetic energy and loses gravitational potential energy ΔE_p . Which of the following statements is true?

- A. ΔE_p is equal to the gain in kinetic energy.
 - B. ΔE_p is greater than the gain in kinetic energy.
 - C. ΔE_p is equal to the work done against air resistance.
 - D. ΔE_p is less than the work done against air resistance.
6. A satellite is in orbit about Earth. The satellite moves to an orbit closer to Earth. Which of the following correctly gives the change in the potential energy and the kinetic energy of the satellite?

	change in potential energy	change in kinetic energy
A.	decreases	increases
B.	decreases	decreases
C.	increases	increases
D.	increases	decreases

7. A brick is placed on the surface of a flat horizontal disc as shown in the diagram below. The disc is rotating at constant speed about a vertical axis through its centre. The brick does not move relative to the disc.

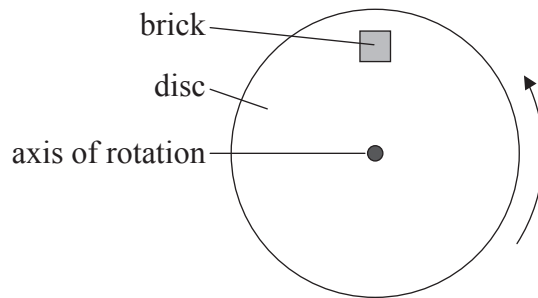

Which of the diagrams below correctly represents the **horizontal** force or forces acting on the brick?

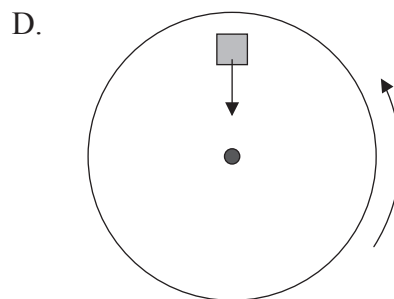
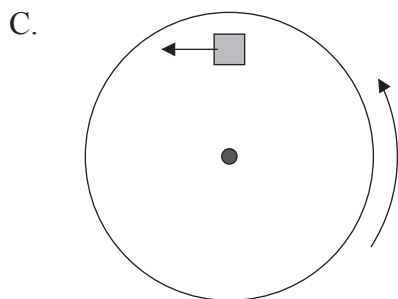
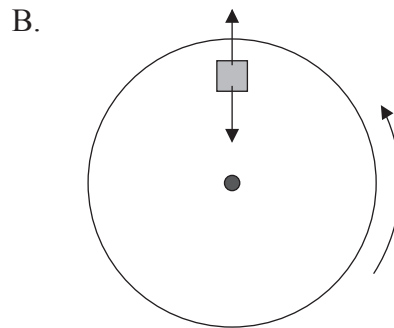
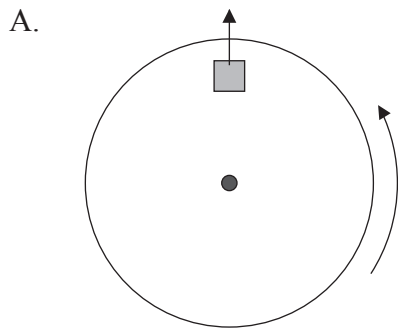

8. A gas is contained in a cylinder fitted with a piston as shown below.

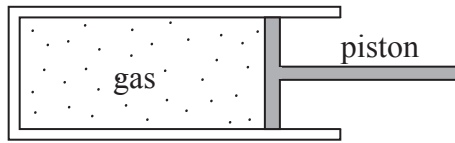

When the gas is compressed rapidly by the piston its temperature rises **because** the molecules of the gas

- A. are squeezed closer together.
 - B. collide with each other more frequently.
 - C. collide with the walls of the container more frequently.
 - D. gain energy from the moving piston.
9. An operating refrigerator with its door open is placed in a thermally insulated room.

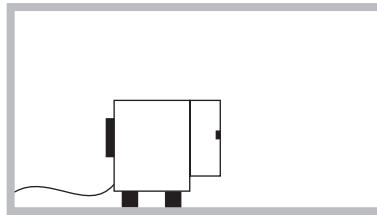

The refrigerator operates for a long period of time. Which of the following correctly gives the change in temperature and the entropy of the air in the room?

	Temperature	Entropy
A.	increases	increases
B.	increases	decreases
C.	decreases	decreases
D.	decreases	increases

10. The graph below shows the variation with time t of the acceleration a of an object from $t=0$ to $t=T$.

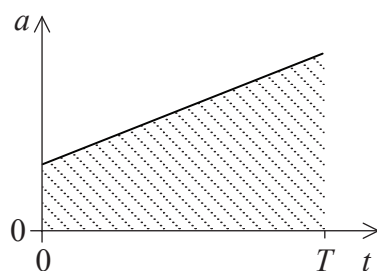

The shaded area under the graph represents change in

- A. displacement.
 - B. velocity.
 - C. momentum.
 - D. kinetic energy.
11. A trolley of mass 1.5 kg is pulled along a horizontal table by a force of 5.0 N.

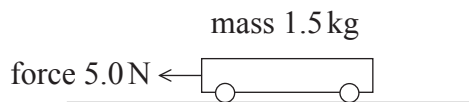

The frictional force acting on the trolley is 0.50 N.

The acceleration of the trolley is

- A. 0.30 ms^{-2} .
- B. 0.33 ms^{-2} .
- C. 3.0 ms^{-2} .
- D. 3.3 ms^{-2} .

12. Planets A and B orbit the same star. The orbital radius of planet B is four times that of planet A.

Which of the following is the magnitude of the ratio

$$\frac{\text{orbital period for planet B}}{\text{orbital period for planet A}}?$$

- A. 4
 - B. 8
 - C. 16
 - D. 64
13. The escape speed of an object of mass m from a planet of mass M and radius r depends on the gravitational constant and
- A. M and r .
 - B. m and r .
 - C. M only.
 - D. M , m , and r .

14. The graph below shows the variation with time t of the displacement x of a particle undergoing simple harmonic motion.

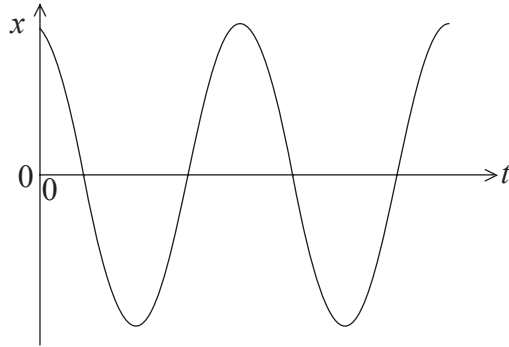

Which graph correctly shows the variation with time t of the acceleration a of the particle?

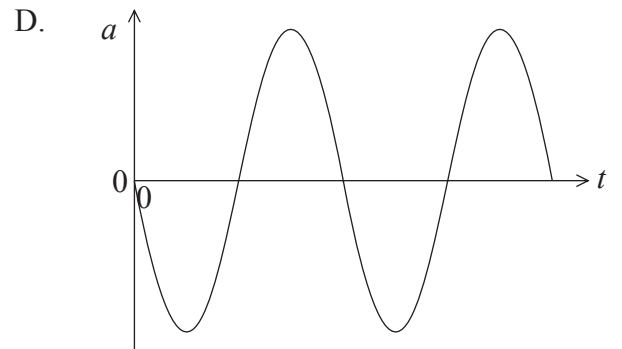
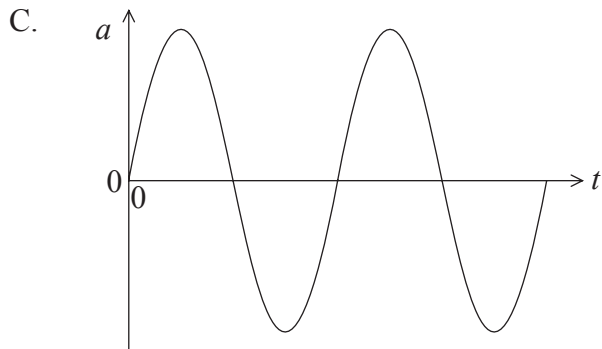
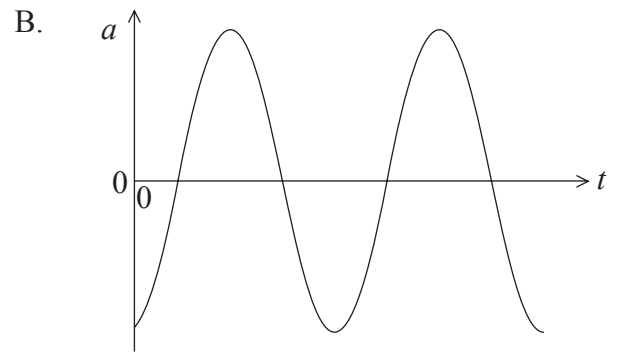
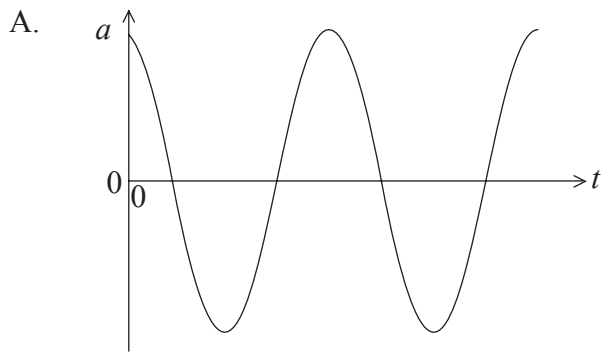

15. A wooden block is at rest on a horizontal frictionless surface. A horizontal spring is attached between the block and a rigid support.

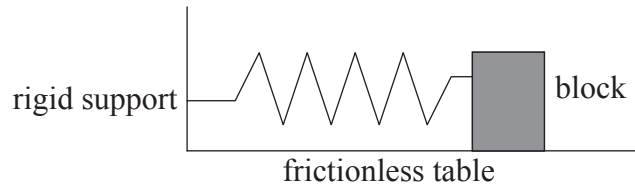

The block is displaced to the right by an amount X and is then released. The period of oscillations is T and the total energy of the system is E .

For an initial displacement of $\frac{X}{2}$ which of the following is the best estimate for the period of oscillations and the total energy of the system?

	Period	Total energy
A.	T	$\frac{E}{2}$
B.	T	$\frac{E}{4}$
C.	$\frac{T}{2}$	$\frac{E}{2}$
D.	$\frac{T}{2}$	$\frac{E}{4}$

16. A block rests on a rough horizontal plane. The plane is gradually tilted at one end until the block begins to slide. The block accelerates down the plane.

Which of the following is a true statement.

- A. The weight of the block equals the dynamic friction force.
 - B. The weight of the block equals the static friction force.
 - C. The dynamic friction force is greater than the static friction force.
 - D. The dynamic friction force is less than the static frictional force.
17. The diagram below shows the trajectory of a ball thrown into the air. There is no air resistance.

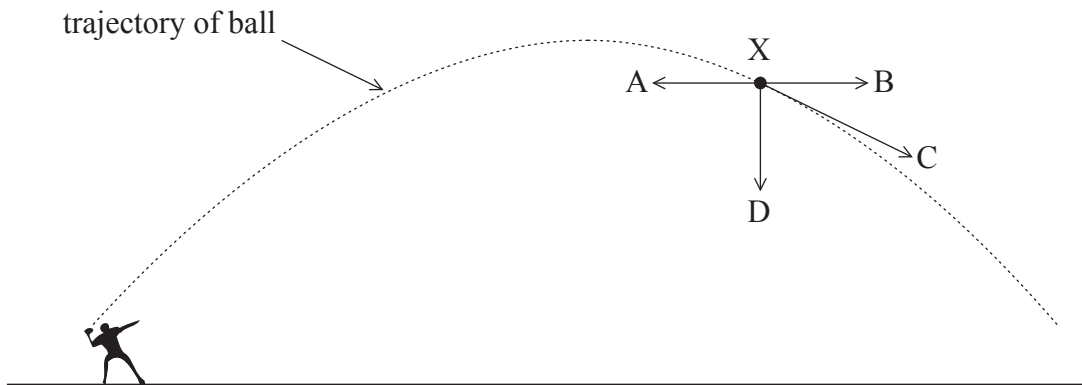

Which arrow gives the direction of the resultant force on the ball at the point X?

- A. A
- B. B
- C. C
- D. D

18. Gas leaks slowly out of a cylinder of constant volume. The temperature of the gas in the cylinder does not change. Which of the following is constant for the gas molecules in the cylinder?
- A. The number striking unit area of surface in unit time
 - B. The number of the collisions between molecules per unit time
 - C. The number per unit volume
 - D. The average speed
19. The graph below shows the variation with absolute temperature T of the pressure p of one mole of an ideal gas having a volume V . R is the molar gas constant.

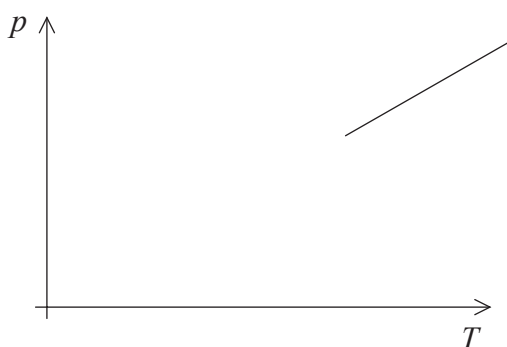

Which of the following is the best interpretation of the intercept on the temperature axis and the gradient of the graph?

	Intercept on temperature axis / K	Gradient of graph
A.	-273	$\frac{R}{V}$
B.	0	$\frac{R}{V}$
C.	0	$\frac{V}{R}$
D.	-273	$\frac{V}{R}$

20. A block of metal at a temperature of 90°C is placed in a beaker of water at a temperature of 0°C . The mass of the metal block and the mass of the water are equal. The final temperature of the water and the metal block is 9°C .

Which of the following is the best estimate of the ratio

$$\frac{\text{specific heat of water}}{\text{specific heat of metal}}?$$

- A. $\frac{1}{10}$
- B. $\frac{1}{9}$
- C. 9
- D. 10

21. The diagram below shows the pressure-volume changes for one cycle PQRS of a Carnot engine.

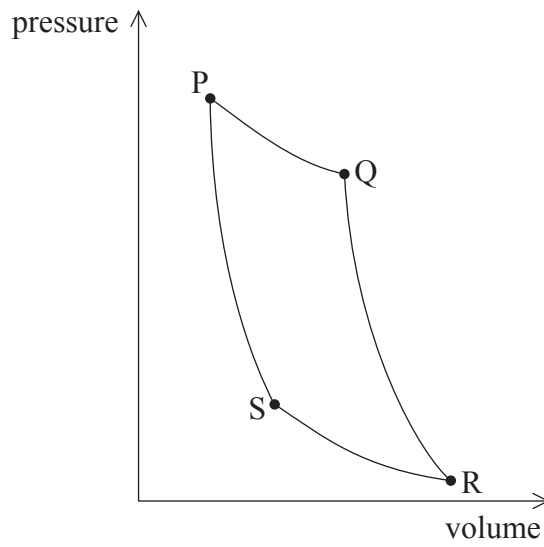

During which part of the cycle is thermal energy transferred to the surroundings?

- A. $P \rightarrow Q$
- B. $Q \rightarrow R$
- C. $R \rightarrow S$
- D. $S \rightarrow P$

22. Unpolarized light of intensity I_0 is incident on a polarizer. The transmitted light is then incident on a second polarizer. The axis of the second polarizer makes an angle of 60° to the axis of the first polarizer.

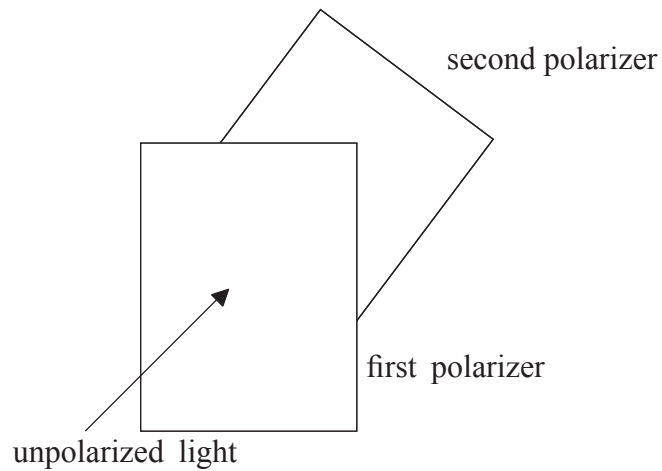

The cosine of 60° is $\frac{1}{2}$. The intensity of the light transmitted through the second polarizer is

- A. I_0 .
 - B. $\frac{I_0}{2}$.
 - C. $\frac{I_0}{4}$.
 - D. $\frac{I_0}{8}$.
23. Two binary stars emit radio waves of wavelength 6.0×10^{-2} m. The waves are received by a radio telescope whose collecting dish has a diameter of 120 m. The two stars are just resolved if their **minimum** angular separation in radians is of the order of
- A. 2×10^4 .
 - B. 2×10^2 .
 - C. 5×10^{-2} .
 - D. 5×10^{-4} .

24. Light travelling from water to air is incident on a boundary.

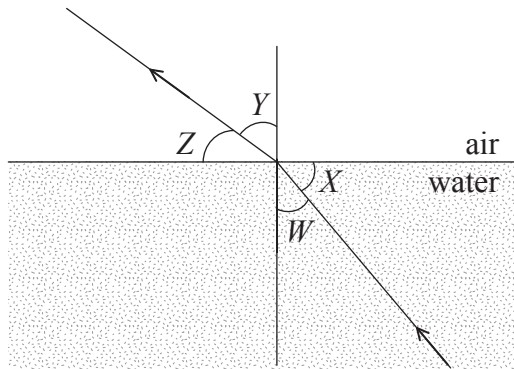

Which of the following is a correct statement of Snell's law for this situation?

- A. $\sin Z = \text{constant} \times \sin Y$
 - B. $\sin W = \text{constant} \times \sin Z$
 - C. $\sin X = \text{constant} \times \sin Z$
 - D. $\sin W = \text{constant} \times \sin Y$
25. A standing wave is established on a string between two fixed points.

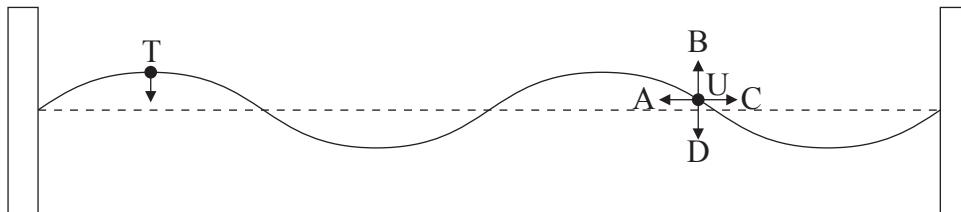

At the instant shown, point T is moving downwards. Which arrow gives the direction of movement of point U at this instant?

- A. A
- B. B
- C. C
- D. D

26. The diagrams below show two standing wave patterns that are set up in a stretched string fixed at both ends. The frequency of pattern 1 is f_1 and that of pattern 2 is f_2 .

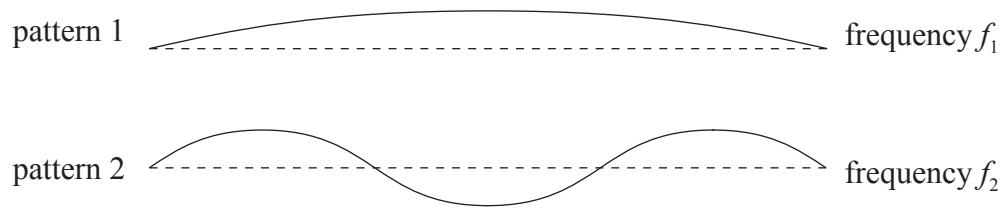

The ratio $\frac{f_1}{f_2}$ is

- A. $\frac{1}{3}$.
- B. $\frac{2}{3}$.
- C. 3.
- D. 6.

27. Sound of a constant frequency f_0 is being emitted by a sound source. An observer O travels in the direction shown at a speed of $0.1v$ where v is the speed of sound.

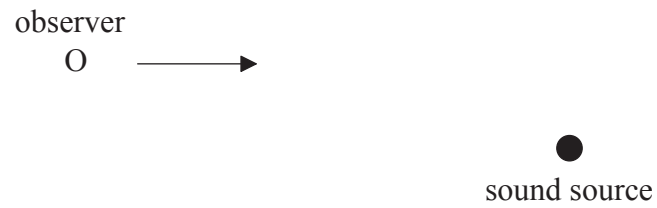

Which of the following gives the relationship between f_0 and the frequency f of observed sound?

- A. $f = 1.1f_0$
- B. $f_0 < f < 1.1f_0$
- C. $f = 0.9f_0$
- D. $f_0 > f > 0.9f_0$

28. The diagram below shows two stationary point charges $+2Q$ and $-Q$.



At which point is the electric field strength greatest?

- A. A
- B. B
- C. C
- D. D

29. The diagram below represents four long straight wires perpendicular to the plane of the paper.

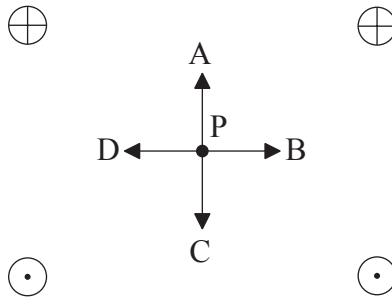

The magnitude of the direct current in each wire is the same. Wires with \oplus have current into the plane of the paper and wires with \ominus have current out of the plane of the paper. Point P is the same distance from each wire.

Which arrow shows the direction of the magnetic field at P?

- A. A
- B. B
- C. C
- D. D

30. Drops of a liquid are being sprayed vertically upwards into the air by a hose in a region where the Earth's magnetic field is directed horizontally as shown in the diagram below.

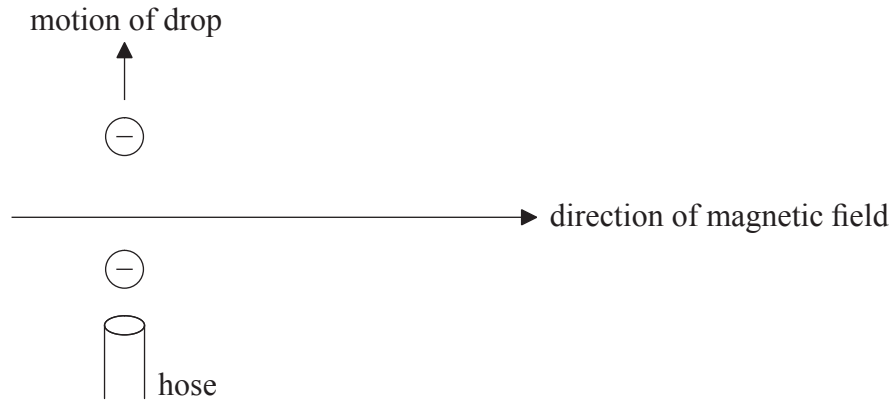

As each drop leaves the hose it becomes negatively charged. Which of the following describes the direction of the magnetic force acting on the drops?

- A. Downwards
 - B. Upwards
 - C. Out of the paper
 - D. Into the paper
31. The diagram below shows the electric field lines in a region of space. A positively charged particle moves from P to Q.

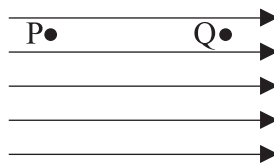

Which of the following is correct?

	Change in potential energy of particle	Change in potential between P and Q
A.	decreases	zero
B.	decreases	negative
C.	increases	zero
D.	increases	negative

32. A metal ring has its plane perpendicular to a magnetic field.

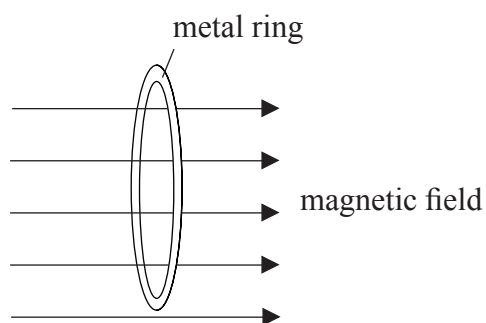

The magnetic flux through the ring increases at a constant rate by 4.0×10^{-5} Wb in 5.0 s.

During this change the e.m.f. induced in the ring

- A. remains constant at $8 \mu\text{V}$.
- B. remains constant at $20 \mu\text{V}$.
- C. increases from zero to $8 \mu\text{V}$.
- D. increases from zero to $20 \mu\text{V}$.

33. In the circuit below, the battery has negligible internal resistance. Three identical lamps L, M and N of constant resistance are connected as shown.

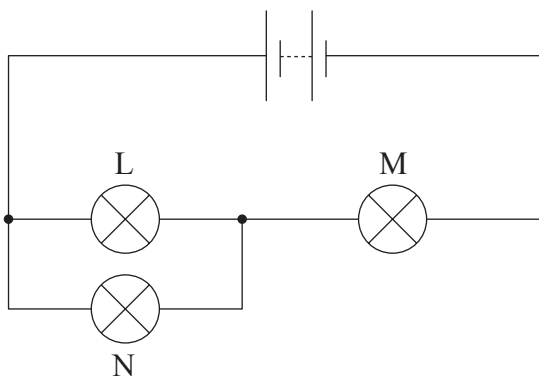

The filament of lamp N breaks. Which of the following shows the subsequent changes to the brightness of lamp L and lamp M?

	Lamp L	Lamp M
A.	stays the same	decreases
B.	increases	stays the same
C.	increases	decreases
D.	decreases	increases

34. An electron is moving in air at right angles to a uniform magnetic field. The diagram below shows the path of the electron. The electron is slowing down.

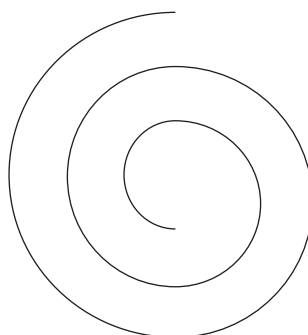

region of magnetic field

Which of the following correctly gives the direction of motion of the electron and the direction of the magnetic field?

	Direction of motion	Direction of magnetic field
A.	clockwise	into plane of paper
B.	clockwise	out of plane of paper
C.	anti-clockwise	into plane of paper
D.	anti-clockwise	out of plane of paper

35. An AC generator produces a voltage of **peak** value V . The frequency of rotation of the coil of the generator is doubled. The **r.m.s.** value of the voltage produced is

- A. $\frac{V}{2\sqrt{2}}$.
- B. $\frac{V}{\sqrt{2}}$.
- C. $V\sqrt{2}$.
- D. $2V\sqrt{2}$.

36. A power station generates electrical energy at a potential difference V and current I . The resistance of the transmission lines between the power station and the consumer is R .

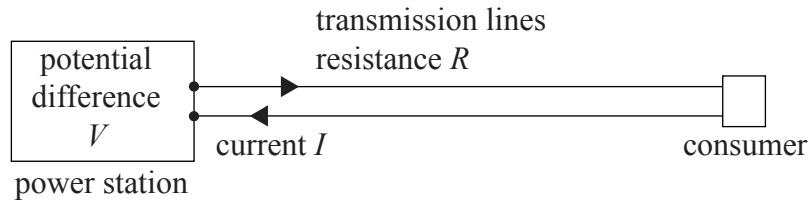

The power lost in the transmission lines is

- A. 0.
- B. $\frac{V^2}{R}$.
- C. RI^2 .
- D. VI .
37. Which of the following provides evidence for de Broglie’s hypothesis concerning matter waves?
- A. Electron diffraction
- B. Atomic energy levels
- C. Nuclear energy levels
- D. The photoelectric effect
38. Which of the following correctly identifies the mass and momentum of a photon?

	Mass	Momentum
A.	zero	zero
B.	zero	non-zero
C.	non-zero	zero
D.	non-zero	non-zero

- 39 A nucleus ${}_{38}^{90}\text{Sr}$ decays by the emission of an electron. What are the mass (nucleon) number and the atomic (proton) number of the resulting nucleus?

	Mass number	Proton number
A.	89	38
B.	90	39
C.	91	38
D.	91	39

40. Radioactive element P has a half-life of 30 days and element Q has a half-life of 20 days. Initially a radioactive source contains equal numbers of each element.

What is the ratio $\frac{\text{number of atoms of P}}{\text{number of atoms of Q}}$ after 60 days have elapsed?

- A. $\frac{1}{2}$
- B. $\frac{2}{3}$
- C. $\frac{3}{2}$
- D. 2