

1. The order of magnitude of the weight of an apple is
- A.  $10^{-4}$  N.
  - B.  $10^{-2}$  N.
  - C. 1 N.
  - D.  $10^2$  N.
2. The density of a metal cube is given by the expression  $\rho = \frac{M}{V}$  where  $M$  is the mass and  $V$  is the volume of the cube. The percentage uncertainties in  $M$  and  $V$  are as shown below.

$M$	12%
$V$	4.0%

The percentage uncertainty in the calculated value of the density is

- A. 3.0%.
- B. 8.0%.
- C. 16%.
- D. 48%.

3. A ball is thrown vertically upwards from the ground. The graph shows the variation with time  $t$  of the vertical displacement  $d$  of the ball.

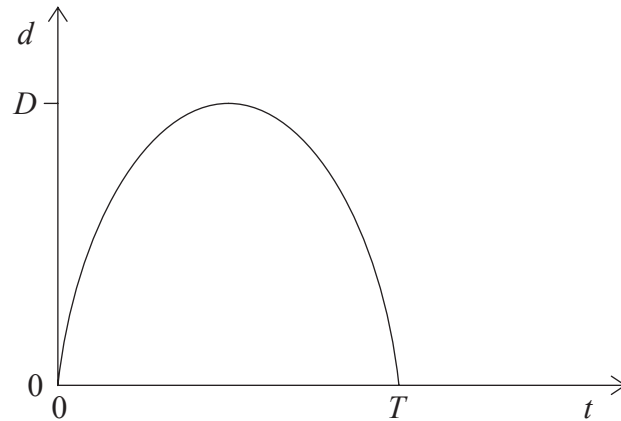

Which of the following gives the final displacement after time  $T$  and the average speed between time  $t = 0$  and time  $t = T$ ?

	<b>Displacement</b>	<b>Average speed</b>
A.	0	0
B.	0	$\frac{2D}{T}$
C.	$2D$	$\frac{2D}{T}$
D.	$2D$	0

4. A general expression for Newton’s second law of motion is

$$F = \frac{\Delta p}{\Delta t}.$$

What condition is applied so that the law may be expressed in the form  $F = ma$ ?

- A. The mass  $m$  is constant.
  - B. The acceleration  $a$  is constant.
  - C. The force  $F$  is constant.
  - D. The direction of the force  $F$  is constant.
5. Mandy stands on a weighing scale inside a lift (elevator) that accelerates vertically upwards as shown in the diagram below. The forces on Mandy are her weight  $W$  and the reaction force from the scale  $R$ .

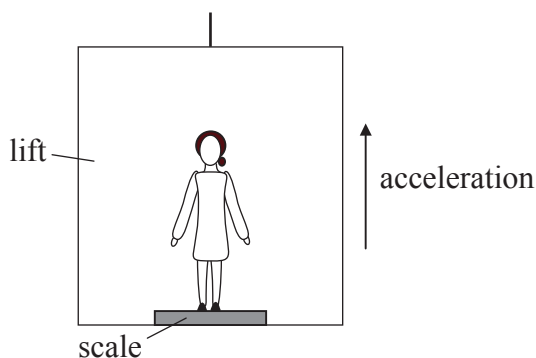

The reading of the scale is

- A.  $R + W$ .
- B.  $W$ .
- C.  $R$ .
- D.  $R - W$ .

9. The internal energy of a solid substance is equal to the
- A. average kinetic energy of the molecules.
  - B. total kinetic energy of the molecules.
  - C. total potential energy of the molecules.
  - D. total potential and total kinetic energy of the molecules.

\*

27. A wind generator produces 5.0 kW of power for a wind speed of  $6.0 \text{ m s}^{-1}$ . The best estimate for the power produced for a wind speed of  $12.0 \text{ m s}^{-1}$  is
- A. 10 kW.
  - B. 25 kW.
  - C. 40 kW.
  - D. 125 kW.
28. It is hypothesized that global warming may lead to significant changes in the average sea-level. This hypothesis assumes that
- A. average rainfall will increase.
  - B. icebergs will melt.
  - C. glaciers will melt.
  - D. the rate of evaporation of seawater will increase.

15. The diagram below shows a pulse travelling along a rope from X to Y. The end Y of the rope is tied to a fixed support.

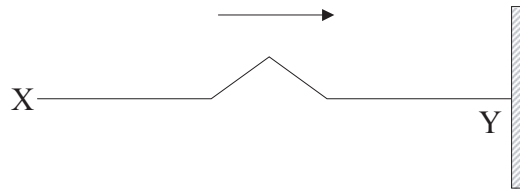

When the pulse reaches end Y it will

- A. disappear.
- B. cause the end of the rope at Y to oscillate up and down.
- C. be reflected and be inverted.
- D. be reflected and not be inverted.

29. Two black bodies X and Y are at different temperatures. The temperature of body Y is higher than that of body X. Which of the following shows the black body spectra for the two bodies?

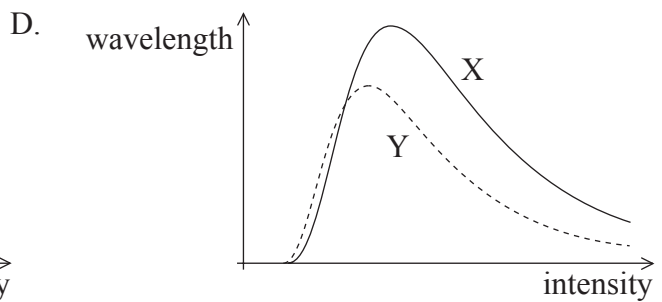
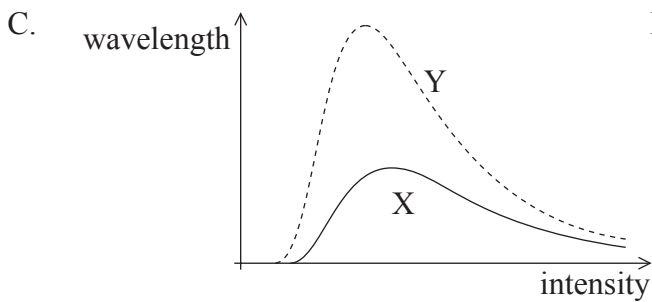
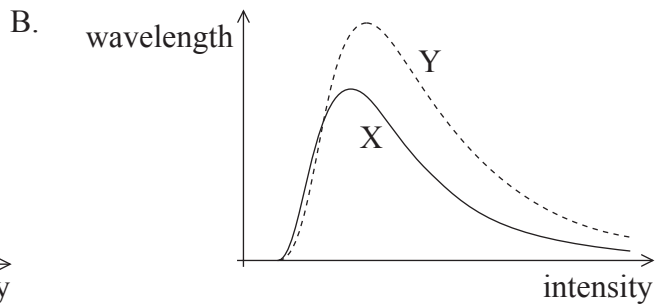
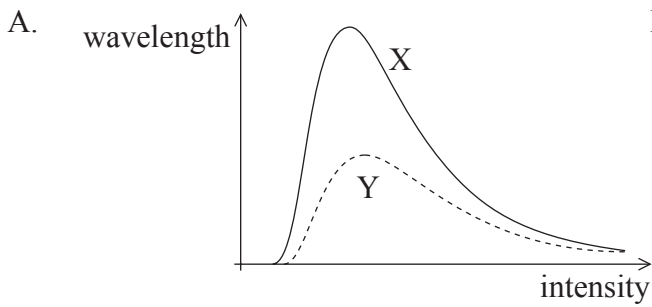

17. In the circuit below, the voltmeter has a resistance  $100\text{ k}\Omega$ . The battery has negligible internal resistance and e.m.f.  $6\text{ V}$ .

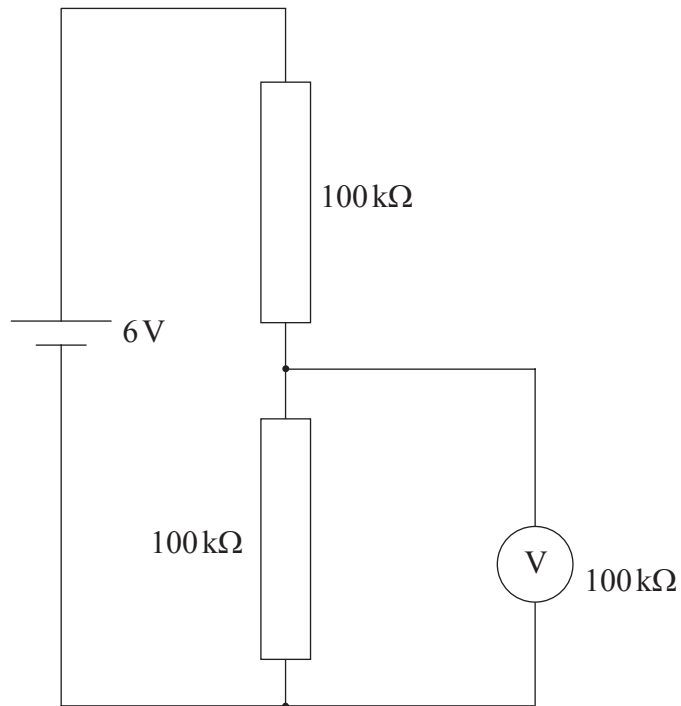

The reading on the voltmeter is

- A.  $0\text{ V}$ .
- B.  $2\text{ V}$ .
- C.  $3\text{ V}$ .
- D.  $4\text{ V}$ .

18. In the circuit shown below, the cell has negligible internal resistance.

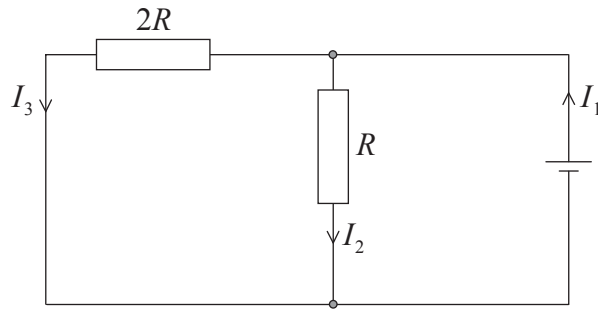

Which of the following equations is correct?

- A.  $I_1 = 2I_2$
- B.  $I_1 = 2I_3$
- C.  $I_2 = 2I_3$
- D.  $I_3 = 2I_1$
19. In Newton's universal law of gravitation the masses are assumed to be
- A. extended masses.
- B. masses of planets.
- C. point masses.
- D. spherical masses.
20. The electric field strength at a point may be defined as
- A. the force exerted on unit positive charge placed at that point.
- B. the force per unit positive charge on a small test charge placed at that point.
- C. the work done on unit positive charge to move the charge to that point from infinity.
- D. the work done per unit positive charge to move a small test charge to that point from infinity.

23. The initial activity of a sample of a radioactive isotope of half-life 10 hours is  $A$ . What is the age of the sample when its activity is  $\frac{A}{32}$ ?

- A. 30 hours
- B. 40 hours
- C. 50 hours
- D. 320 hours

24. When the isotope aluminium-27 is bombarded with alpha particles, the following nuclear reaction can take place.

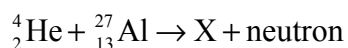

Which of the following correctly gives the atomic (proton) number and mass (nucleon) number of the nucleus X?

	Proton number	Nucleon number
A.	15	30
B.	16	31
C.	30	15
D.	31	16

25. The volume of a given mass of water at a temperature of  $T_1$  is  $V_1$ . The volume increases to  $V_2$  at temperature  $T_2$ . The coefficient of volume expansion of water may be calculated from

- A.  $\frac{V_2 - V_1}{T_2 - T_1}$ .
- B.  $\frac{V_2 - V_1}{T_2 - T_1}$ .
- C.  $\frac{V_2 - V_1}{V_1(T_2 - T_1)}$ .
- D.  $\frac{V_2 - V_1}{V_2(T_2 - T_1)}$ .

30. The diagram below shows a simplified model of the energy balance for Earth.

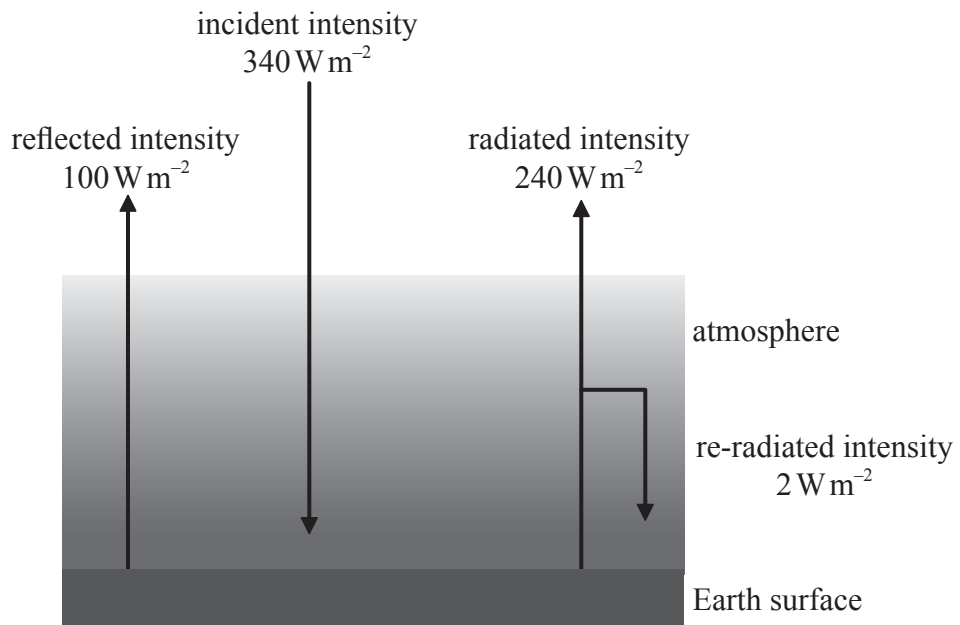

The albedo of the Earth according to this model is equal to

- A.  $\frac{2}{340}$
  - B.  $\frac{100}{340}$
  - C.  $\frac{238}{340}$
  - D.  $\frac{240}{340}$
-

3. The diagram below shows two vectors  $X$  and  $Y$ .

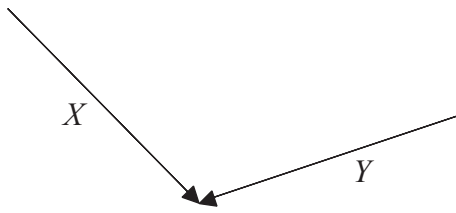

Which of the following best represents the vector  $Z = X - Y$ .

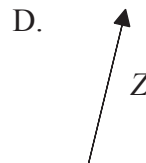
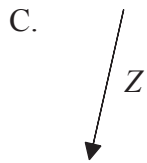
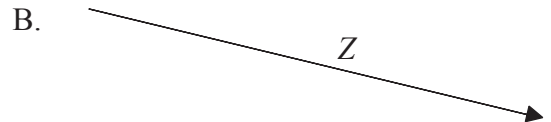
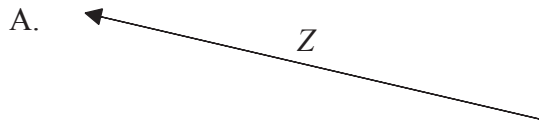

4. Which of the following graphs shows the best-fit line for the plotted points?

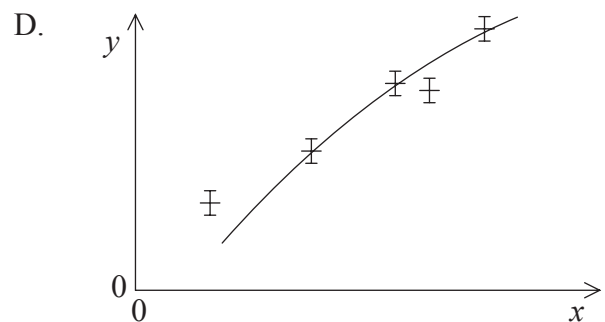
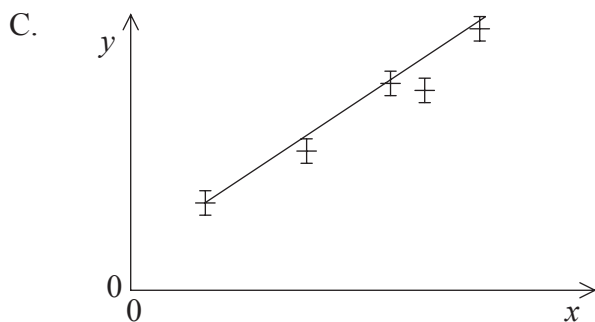
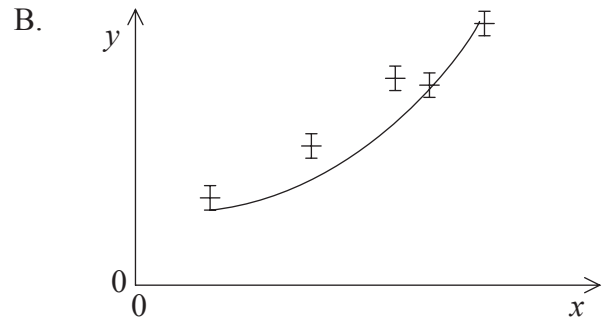
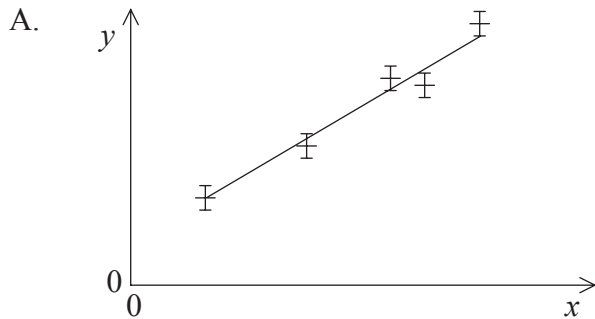

5. A car has a speed of  $+15 \text{ m s}^{-1}$  relative to the ground. It passes a cyclist travelling in the same straight-line. The speed of the car relative to the cyclist is  $+12 \text{ m s}^{-1}$ .

The speed of the cyclist relative to the ground is

- A.  $-3.0 \text{ m s}^{-1}$ .
  - B.  $-1.5 \text{ m s}^{-1}$ .
  - C.  $+1.5 \text{ m s}^{-1}$ .
  - D.  $+3.0 \text{ m s}^{-1}$ .
6. A steel sphere is dropped from rest in oil. Which of the following graphs best represents the variation with time of the speed of the sphere?

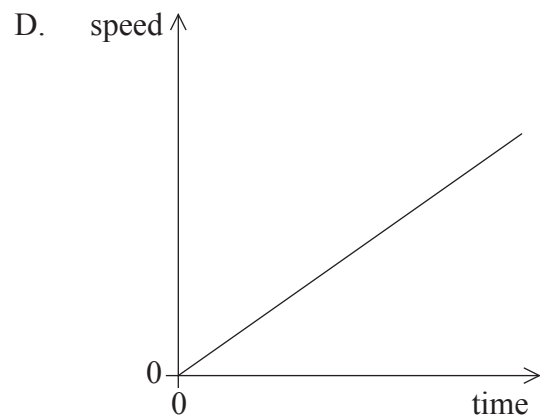
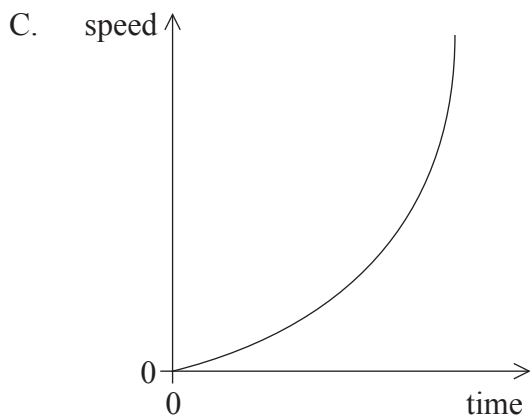
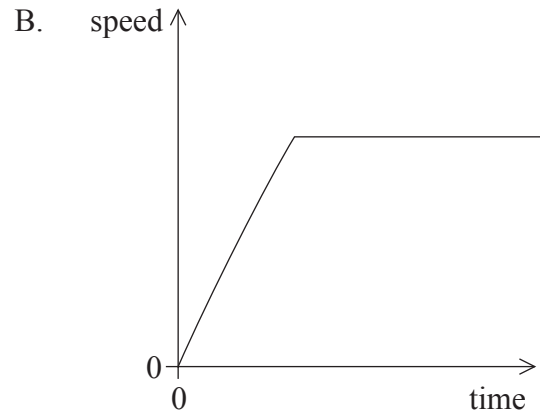
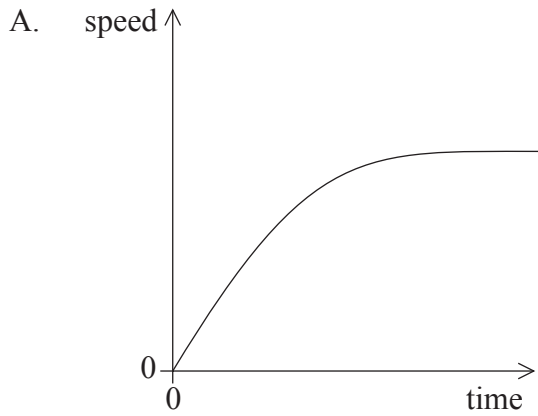

Questions 8 and 9 both refer to the following information and graph.

The graph below shows the variation with load of the length of a spring.

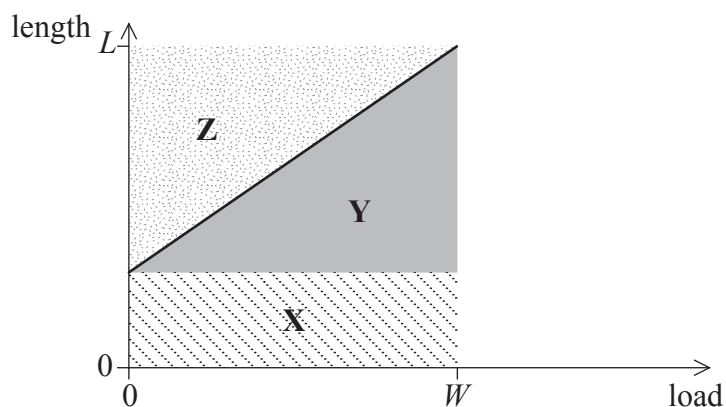

For a load  $W$  the length of the spring is  $L$ .

8. Which of the following areas on the graph represents the energy stored in the spring when it is stretched to a length  $L$ ?
- A. X
  - B.  $Y - X$
  - C. Z
  - D.  $X + Y$
9. The spring constant of the spring is given by
- A. the gradient of the graph.
  - B.  $\frac{1}{\text{gradient of the graph}}$ .
  - C.  $\frac{W}{L}$ .
  - D.  $\frac{L}{W}$ .

10. A fireman is holding a hosepipe so that water leaves the pipe horizontally. The hosepipe has a constant cross-sectional area. The magnitude of the force that the fireman exerts to hold the hosepipe stationary is  $F$ .

The volume of water delivered by the hose per second doubles, the force that the fireman must now exert is

- A.  $\sqrt{2}F$ .
- B.  $2F$ .
- C.  $4F$ .
- D.  $8F$ .
11. An object of mass  $m$  falls from rest in a vacuum. As the object falls it loses an amount  $E$  of gravitational potential energy. The speed of the object is then

- A.  $\sqrt{\frac{2E}{m}}$ .
- B.  $\sqrt{\frac{m}{2E}}$ .
- C.  $\frac{2E}{m}$ .
- D.  $\frac{m}{2E}$ .

14. An impulse  $I$  acts on a body of mass  $m$  that is initially at rest. What is the distance moved by the body in a time  $t$  after the impulse has been delivered?

A.  $\frac{It}{m}$

B.  $\frac{Im}{t}$

C.  $\frac{I}{m}$

D.  $It$

15. Which of the following will **not** affect the rate of evaporation of a liquid?

A. The temperature of the liquid

B. The surface area of the liquid

C. The mass of the liquid

D. Convection currents of air above the liquid surface

20. A standing wave is established on a string between two fixed points.

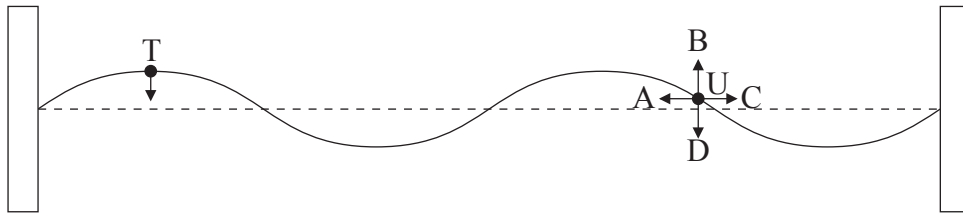

At the instant shown, point T is moving downwards. Which arrow gives the direction of movement of point U at this instant?

- A. A
- B. B
- C. C
- D. D

21. A pulse is travelling along a string attached to a wall.

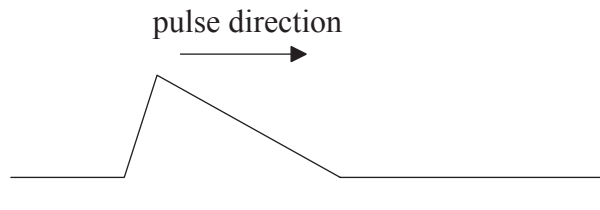

Which of the following shows the shape of the string after reflection from the wall?

