

SECTION A

Answer **all** the questions in the spaces provided.

A1. The question is about investigating a fireball caused by an explosion.

When a fire burns within a confined space, the fire can sometimes spread very rapidly in the form of a circular fireball. Knowing the speed with which these fireballs can spread is of great importance to fire-fighters. In order to be able to predict this speed, a series of controlled experiments was carried out in which a known amount of petroleum (petrol) stored in a can was ignited.

The radius R of the resulting fireball produced by the explosion of some petrol in a can was measured as a function of time t . The results of the experiment for five different volumes of petroleum are shown plotted below. (Uncertainties in the data are not shown.)

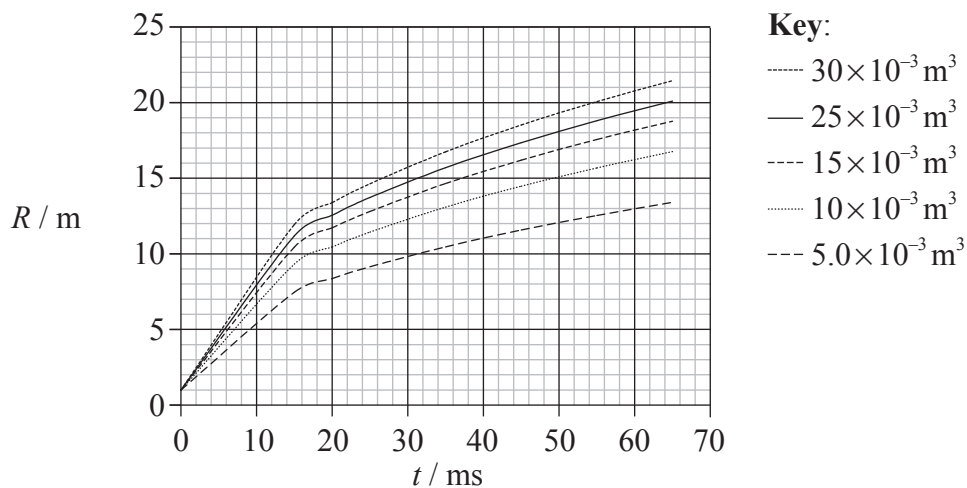

(a) The original hypothesis was that, for a given volume of petrol, the radius R of the fireball would be directly proportional to the time t after the explosion. State **two** reasons why the plotted data do not support this hypothesis. [2]

1.
-
-
2.
-
-

(This question continues on the following page)



(Question A1 continued)

- (b) The uncertainty in the radius is ± 0.5 m. The addition of error bars to the data points would show that there is in fact a systematic error in the plotted data. Suggest **one** reason for this systematic error. [2]

.....

.....

.....

.....

- (c) Since the data do not support direct proportionality between the radius R of the fireball and time t , a relation of the form

$$R = kt^n$$

is proposed, where k and n are constants.

In order to find the value of k and of n , $\lg(R)$ is plotted against $\lg(t)$. The resulting graph, for a particular volume of petrol, is shown below. (Uncertainties in the data are not shown.)

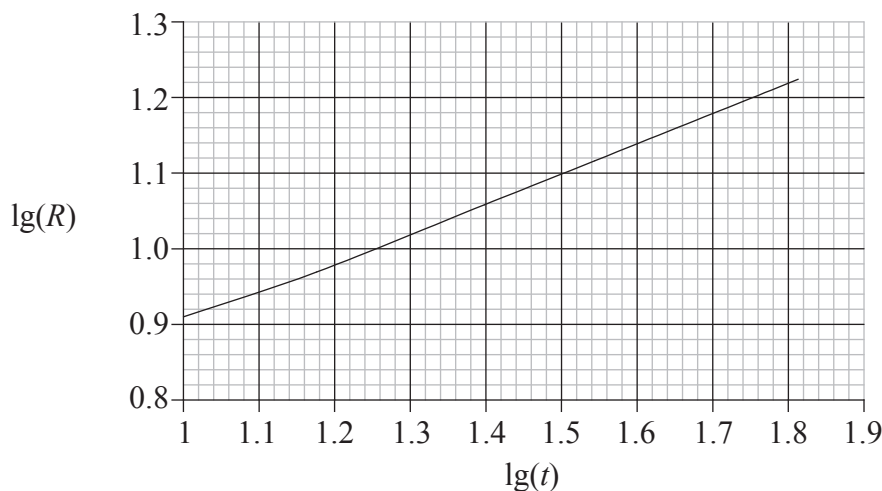

Use this graph to deduce that the radius R is proportional to $t^{0.4}$. Explain your reasoning. [4]

.....

.....

.....

.....

.....

.....

(This question continues on the following page)



(Question A1 continued)

- (d) It is known that the energy released in the explosion is proportional to the initial volume of petrol. A hypothesis made by the experimenters is that, at a given time, the radius of the fireball is proportional to the energy E released by the explosion. In order to test this hypothesis, the radius R of the fireball 20 ms after the explosion was plotted against the initial volume V of petrol causing the fireball. The resulting graph is shown below.

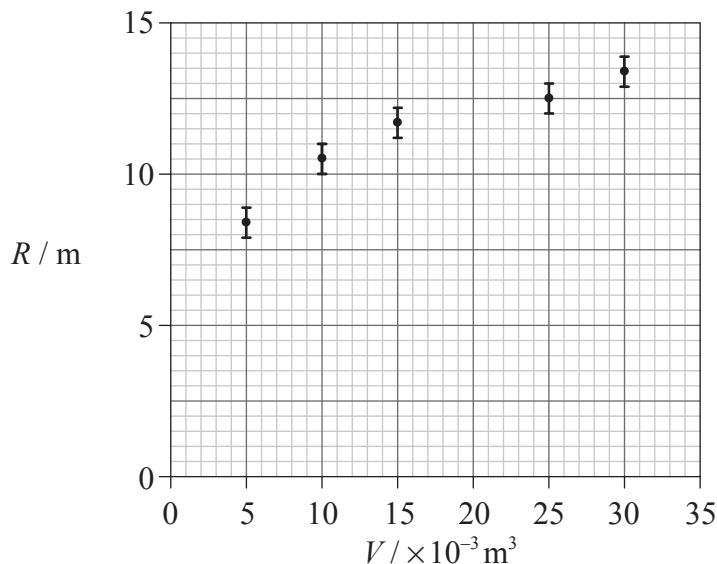

The uncertainties in R have been included. The uncertainty in the volume of petrol is negligible.

- (i) Describe how the data for the above graph are obtained from the graph in (a). [1]

.....
.....

- (ii) Draw the line of best-fit for the data points. [2]

- (iii) Explain whether the plotted data together with the error bars support the hypothesis that R is proportional to V . [2]

.....
.....
.....
.....
.....

(This question continues on the following page)



(Question A1 continued)

- (e) Analysis shows that the relation between the radius R , energy E released and time t is in fact given by

$$R^5 = Et^2.$$

Use data from the graph in (d) to deduce that the energy liberated by the combustion of $1.0 \times 10^{-3} \text{ m}^3$ of petrol is about 30 MJ.

[4]

.....

.....

.....

.....

.....



A2. This question is about electric circuits.

(a) Define e.m.f. and state Ohm's law.

[2]

e.m.f.:

Ohm's law:

(b) In the circuit below an electrical device (load) is connected in series with a cell of e.m.f. 2.5 V and internal resistance r . The current I in the circuit is 0.10 A.

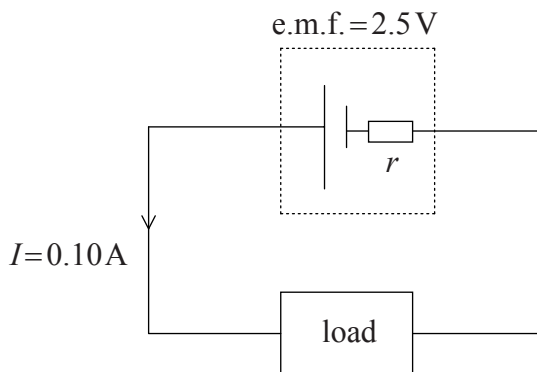

The power dissipated in the load is 0.23 W.

Calculate

(i) the total power of the cell.

[1]

.....

(ii) the resistance of the load.

[2]

.....

(iii) the internal resistance r of the cell.

[2]

.....

(This question continues on the following page)



(Question A2 continued)

(c) A second identical cell is connected into the circuit in (b) as shown below.

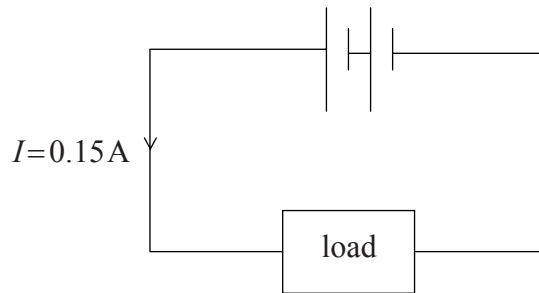

The current in this circuit is 0.15 A. Deduce that the load is a non-ohmic device.

[4]

.....

.....

.....

.....

.....

.....



A3. This question is about X-rays.

- (a) Using the axes below, draw a sketch-graph of a typical X-ray spectrum that includes a characteristic spectrum. Label the characteristic spectrum with the letter C. [3]

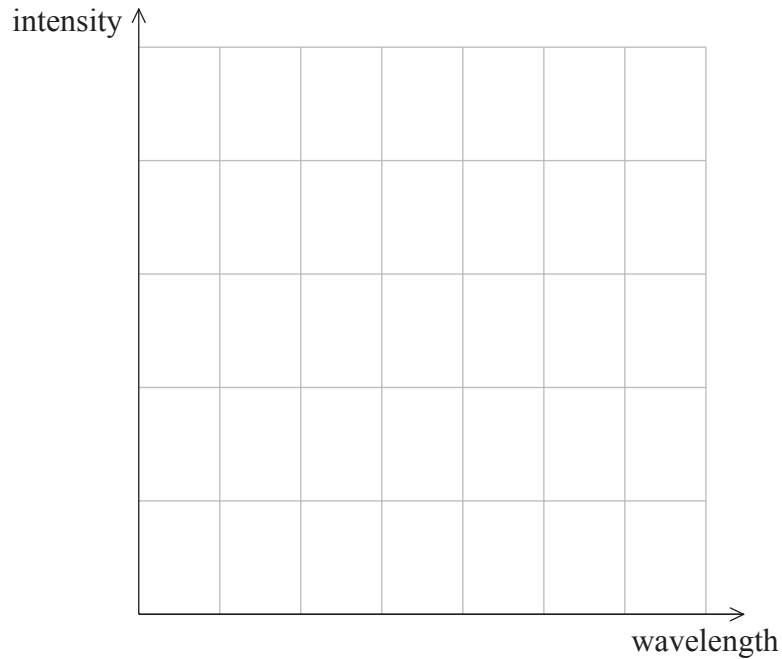

- (b) The X-ray spectrum of molybdenum has a particular characteristic spectral line of wavelength 6.6×10^{-11} m. The ionisation energy of molybdenum is 20 keV.

- (i) Deduce that the energy of an X-ray photon of wavelength 6.6×10^{-11} m is 19 keV. [2]

.....
.....
.....

- (ii) The characteristic spectral line of wavelength 6.6×10^{-11} m is produced by electrons making transitions between an excited energy level and the ground state energy level of the molybdenum atom. Calculate, in electron-volts, the excited energy level. [2]

.....
.....
.....



Blank page



SECTION B

*This section consists of four questions: B1, B2, B3 and B4. Answer **two** questions.*

B1. This question is about Newton’s laws of motion, the dynamics of a model helicopter and the engine that powers it.

(a) Explain how Newton’s third law leads to the concept of conservation of momentum in the collision between two objects in an isolated system. [4]

.....
.....
.....
.....
.....
.....
.....
.....
.....
.....

(b) The diagram illustrates a model helicopter that is hovering in a stationary position.

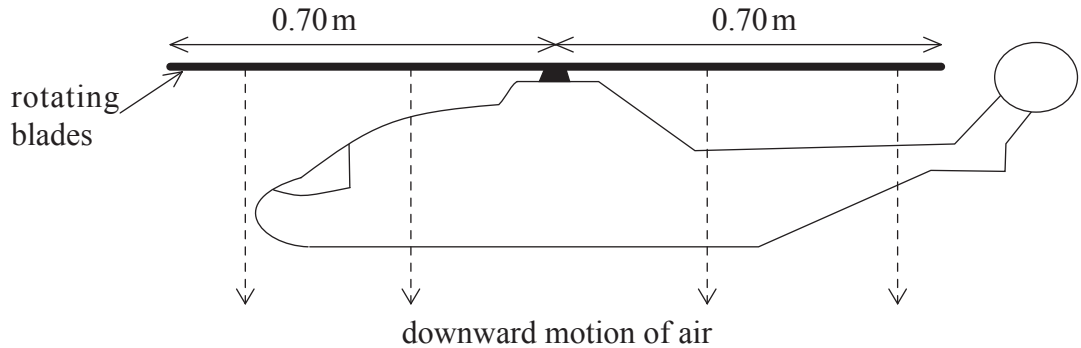

The rotating blades of the helicopter force a column of air to move downwards. Explain how this may enable the helicopter to remain stationary. [3]

.....
.....
.....
.....
.....
.....

(This question continues on the following page)



(Question B1 continued)

- (c) The length of each blade of the helicopter in (b) is 0.70 m. Deduce that the area that the blades sweep out as they rotate is 1.5 m^2 . (Area of a circle = πr^2) [1]

.....

.....

- (d) For the hovering helicopter in (b), it is assumed that all the air beneath the blades is pushed vertically downwards with the same speed of 4.0 m s^{-1} . No other air is disturbed.

The density of the air is 1.2 kg m^{-3} .

Calculate, for the air moved downwards by the rotating blades,

- (i) the mass per second. [2]

.....

.....

.....

.....

- (ii) the rate of change of momentum. [1]

.....

.....

- (e) State the magnitude of the force that the air beneath the blades exerts on the blades. [1]

.....

- (f) Calculate the mass of the helicopter and its load. [2]

.....

.....

.....

.....

(This question continues on the following page)



(Question B1 continued)

- (g) In order to move forward, the helicopter blades are made to incline at an angle θ to the horizontal as shown schematically below.

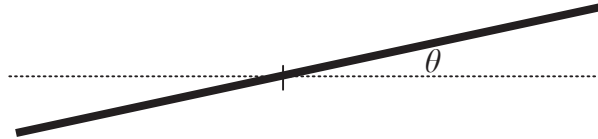

While moving forward, the helicopter does not move vertically up or down. In the space provided below draw a free body force diagram that shows the forces acting on the helicopter blades at the moment that the helicopter starts to move forward. On your diagram, label the angle θ .

[4]

(This question continues on the following page)



(Question B1 continued)

- (h) Use your diagram in (g) opposite to explain why a forward force F now acts on the helicopter and deduce that the initial acceleration a of the helicopter is given by

$$a = g \tan \theta$$

where g is the acceleration of free fall.

[5]

.....

.....

.....

.....

.....

.....

.....

.....

.....

.....

- (i) The helicopter is driven by an engine that has a useful power output of 9.0×10^2 W. The engine makes 300 revolutions per second. Deduce that the work done in one cycle is 3.0J. [1]

.....

.....

(This question continues on the following page)



(Question B1 continued)

- (j) The diagram below shows the relation between the pressure and the volume of the air in the engine for one cycle of operation of the engine.

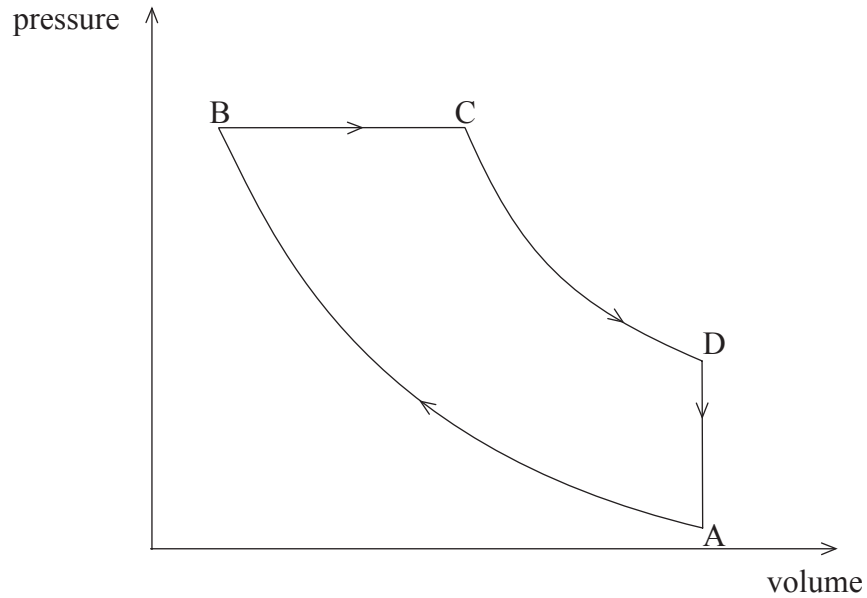

- (i) State the name given to the type of process represented by D→A. [1]

.....

- (ii) During one cycle of the engine, the gas absorbs Q_1 units of thermal energy and Q_2 units of thermal energy are transferred from the gas. On the diagram above, draw labelled arrows to show these energy transfers. [2]

- (iii) The efficiency of the engine is 60%. Using your answer to question (i) on page 13, calculate the values of Q_1 and Q_2 . [3]

.....
.....
.....
.....
.....



B2. This question is in **two** parts. **Part 1** is about some properties of waves associated with the principle of superposition. **Part 2** is about the gravitational field associated with a neutron star.

Part 1 Waves

Stationary (standing) waves and resonance

(a) State **two** ways in which a standing wave differs from a continuous wave. [2]

1.
.....

2.
.....

(b) State the principle of superposition as applied to waves. [2]

.....
.....
.....
.....

(This question continues on the following page)



(Question B2, part 1 continued)

- (c) A stretched string is fixed at one end. The other end is vibrated continuously to produce a wave along the string. The wave is reflected at the fixed end and as a result a standing wave is set up in the string.

The diagram below shows the displacement of the string at time $t=0$. The dotted line shows the equilibrium position of the string.

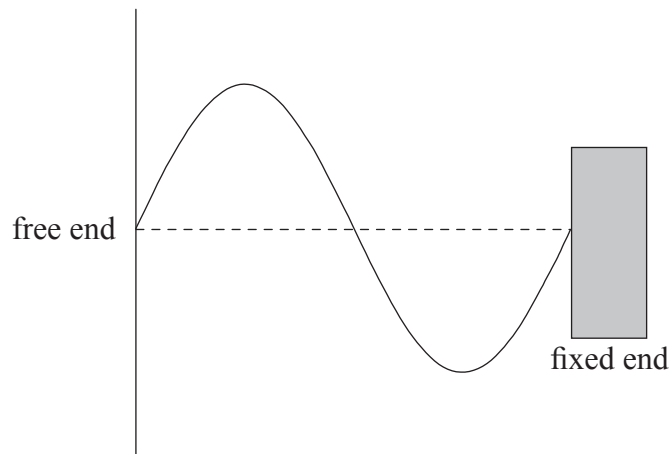

(This question continues on the following page)



(Question B2, part 1 continued)

- (i) The period of oscillation of the string is T . On the diagrams below, draw sketches of the displacement of the string at time $t = \frac{T}{4}$ and at time $t = \frac{T}{2}$. [2]

$$t = \frac{T}{4}$$

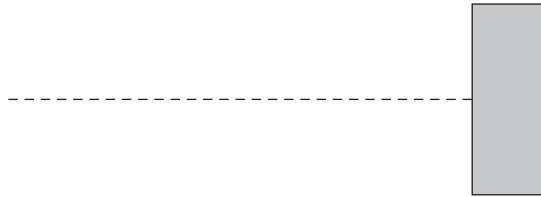

$$t = \frac{T}{2}$$

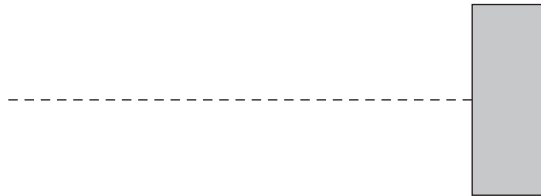

- (ii) Use your sketches in (i) to explain why the wave in the string appears to be stationary. [2]

.....
.....
.....
.....

(This question continues on the following page)



(Question B2, part 1 continued)

(d) Stationary waves are often associated with the phenomenon of resonance.

(i) Describe what is meant by *resonance*. [2]

.....
.....
.....
.....

(ii) On 19 September 1985 an earthquake occurred in Mexico City. Many buildings that were about 80 m tall collapsed whereas buildings that were taller or shorter than this remained undamaged. Use the data below to suggest a reason for this. [3]

period of oscillation of an 80 m tall building = 2.0 s
speed of earthquake waves = $6.0 \times 10^3 \text{ m s}^{-1}$
average wavelength of the waves = $1.2 \times 10^4 \text{ m}$

.....
.....
.....
.....
.....

(This question continues on page 20)



Blank page



(Question B2, part 1 continued from page 18)

Beats

- (e) Two sound sources X and Y have the same intensity but different frequencies. The graph below shows the variation with time t of the displacement y of the air at point P when source X is sounded alone.

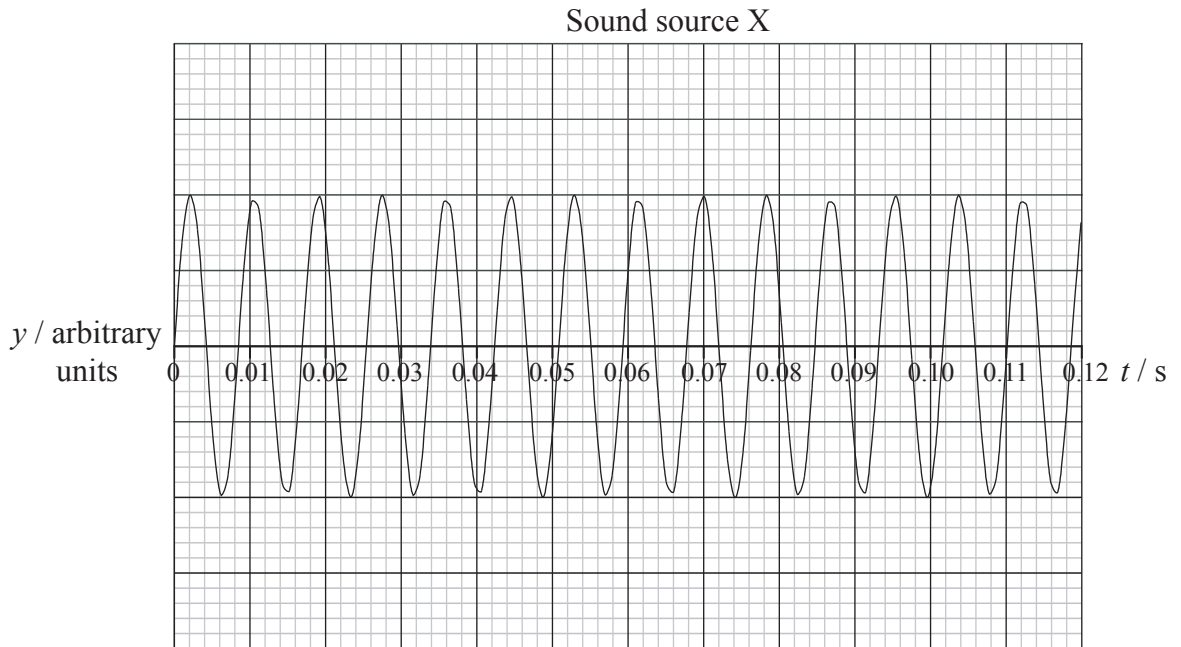

The graph below shows the variation with time t of the displacement y of the air at point P when source X and source Y are sounded together.

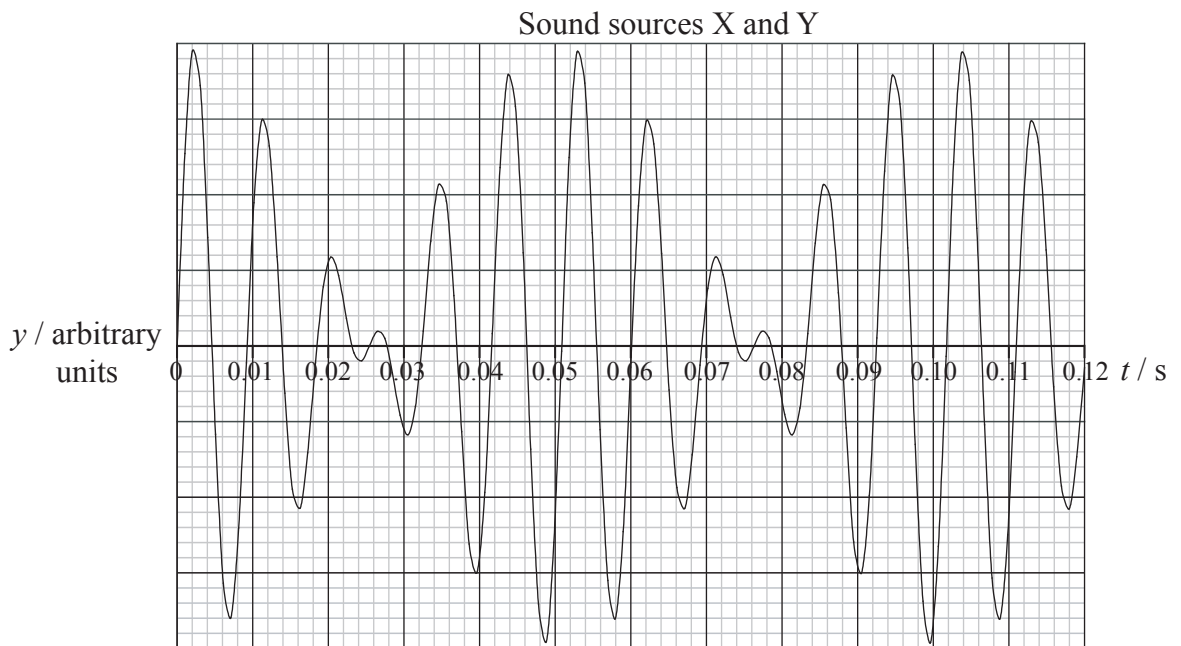

(This question continues on the following page)



(Question B2, part 1 continued)

Use data from the graphs

- (i) to explain what is heard by an observer at point P. [2]

.....
.....
.....
.....

- (ii) to calculate the beat frequency and the frequency of the sound source X. [4]

.....
.....
.....
.....
.....
.....

- (f) State **one** of the possible values for the frequency of sound source Y. [1]

.....

(This question continues on the following page)



(Question B2 continued)

Part 2 Neutron star

- (a) Define *gravitational field strength*. [2]

.....

.....

.....

- (b) Neutron stars are very dense stars of small radius. They are formed as part of the evolutionary process of stars that are much more massive than the Sun.

A particular neutron star has radius R of 1.6×10^4 m. The gravitational field strength at its surface is g_0 . The escape speed v_e from the surface of the star is 3.6×10^7 m s⁻¹.

- (i) The gravitational potential V at the surface of the star is equal to $-g_0R$. Deduce, explaining your reasoning, that the escape speed from the surface of the star is given by the expression

$$v_e = \sqrt{2g_0R}. \tag{3}$$

.....

.....

.....

.....

.....

- (ii) Calculate the gravitational field strength at the surface of the neutron star. [2]

.....

.....

.....

.....

(This question continues on the following page)



(Question B2, part 2 continued)

- (c) The period T of rotation of the neutron star is 0.02 s. Use your answer to (b)(ii) to deduce that matter is not lost from the surface of the star as a result of its high speed of rotation. [3]

.....

.....

.....

.....

.....



Blank page



B3. This question is in **two** parts. **Part 1** is about gases and liquids. **Part 2** is about electrical conduction and induced currents.

Part 1 Gases and liquids

(a) Describe **two** differences, in terms of molecular structure, between a gas and a liquid. [2]

- 1.
.....
- 2.
.....

(b) The temperature of an ideal gas is a measure of the average kinetic energy of the molecules of the gas. Explain why the **average** kinetic energy is specified. [2]

.....
.....
.....
.....

(c) Define *heat (thermal) capacity*. [1]

.....
.....

(This question continues on the following page)



(Question B3, part 1 continued)

- (d) Water is heated at a constant rate in a container that has negligible heat capacity. The container is thermally insulated from the surroundings.

The sketch-graph below shows the variation with time of the temperature of the water.

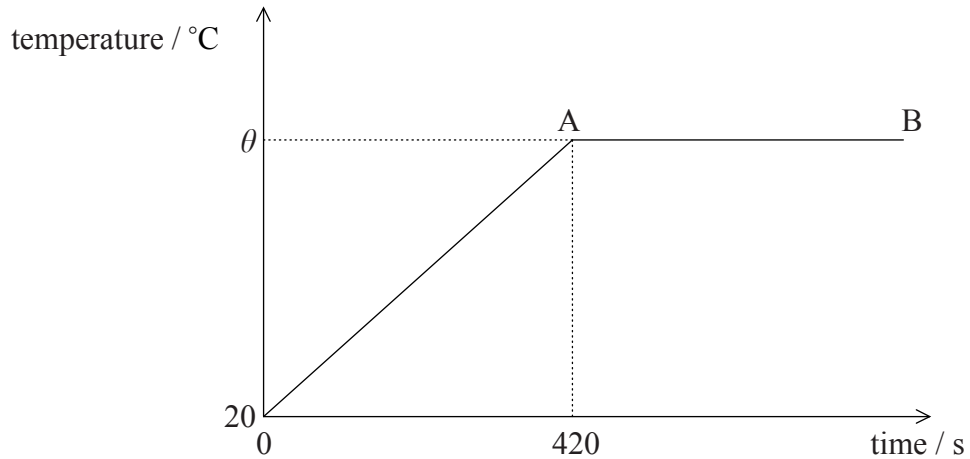

The following data are available:

- initial mass of water = 0.40 kg
- initial temp of water = 20 °C
- rate at which water is heated = 300 W
- specific heat capacity of water = $4.2 \times 10^3 \text{ J kg}^{-1} \text{ °C}^{-1}$

- (i) State the reason why the temperature is constant in the region A→B. [1]

.....
.....

- (ii) Calculate the temperature θ at which the water starts to boil. [5]

.....
.....
.....
.....
.....
.....
.....
.....
.....

(This question continues on the following page)



(Question B3, part 1 continued)

- (e) All the water is boiled away 3.0×10^3 s after it first starts to boil. Determine a value for the specific latent heat L of vaporisation of water. [2]

.....
.....
.....
.....

(This question continues on the following page)



(Question B3 continued)

Part 2 Electrical conduction and induced currents

- (a) The diagram below shows a copper rod inside which an electric field of strength E is maintained by connecting the copper rod in series with a cell. (Connections to the cell are not shown.)

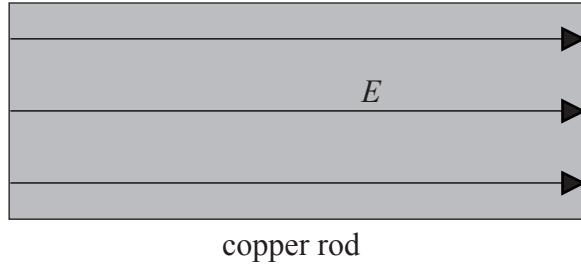

Describe how the electric field enables the conduction electrons to have a drift velocity in a direction along the copper rod.

[3]

.....

.....

.....

.....

.....

(This question continues on the following page)

(Question B3, part 2 continued)

- (b) A copper rod is placed on two parallel, horizontal conducting rails PQ and SR as shown below.

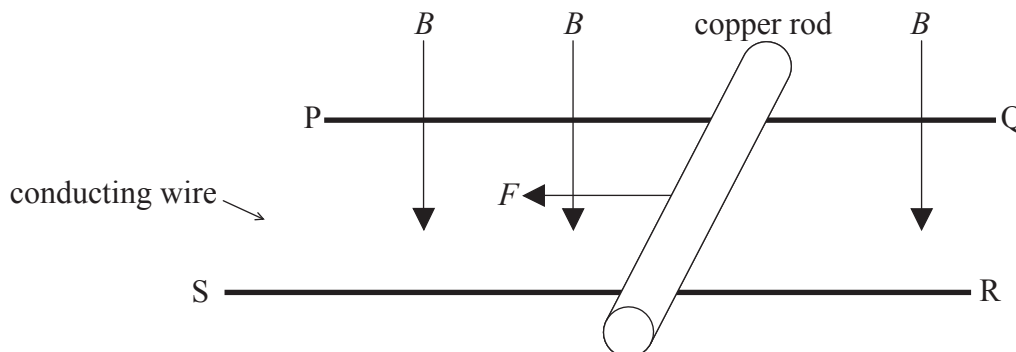

The rails and the copper rod are in a region of uniform magnetic field of strength B . The magnetic field is normal to the plane of the conducting rods as shown in the diagram above.

A conducting wire is connected between the ends P and S of the rails. A constant force, parallel to the rails, of magnitude F is applied to the copper rod in the direction shown. The copper rod moves along the rails with a decreasing acceleration.

- (i) On the diagram, draw an arrow to show the direction of induced current in the copper rod. Label this arrow with the letter I. [1]

- (ii) Explain, by reference to Lenz's law, why the induced current is in the direction you have shown in (i). [2]

.....

- (iii) By considering the forces on the conduction electrons in the copper rod, explain why the acceleration of the copper rod decreases as it moves along the rails. [3]

.....

(This question continues on the following page)



(Question B3, part 2 continued)

- (c) The copper rod in (b) eventually moves with constant speed v . The induced e.m.f. \mathcal{E} in the copper rod is given by the expression

$$\mathcal{E} = Bvl$$

where l is the length of copper rod in the region of uniform magnetic field.

- (i) State Faraday’s law of electromagnetic induction. [1]

.....

- (ii) Deduce that the expression is consistent with Faraday’s law. [3]

.....

- (iii) The following data are available:

$$F = 0.32 \text{ N}$$

$$l = 0.40 \text{ m}$$

$$B = 0.26 \text{ T}$$

$$\text{resistance of copper rod} = 0.15 \Omega$$

Determine the induced current and the speed v of the copper rod. [4]

Induced current:

Speed v :



B4. This question is in **two** parts. **Part 1** is about radioactive decay. **Part 2** is about friction.

Part 1 Radioactive decay

(a) The nucleon number (mass number) of a stable isotope of argon is 36 and of a radioactive isotope of argon is 39.

(i) State what is meant by a *nucleon*. [1]

.....
.....

(ii) Outline the structure of nucleons in terms of quarks. [2]

.....
.....

(iii) Explain, in terms of the number of nucleons and the forces between them, why argon-36 is stable and argon-39 is radioactive. [4]

.....
.....
.....
.....
.....

(This question continues on the following page)



(Question B4, part 1 continued)

- (b) Argon-39 undergoes β^- decay to an isotope of potassium (K). The nuclear reaction equation for this decay is

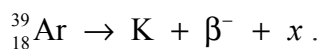

- (i) State the proton (atomic) number and the nucleon (mass) number of the potassium nucleus and identify the particle x . [3]

Proton number:

Nucleon number:

Particle x :

- (ii) The existence of the particle x was postulated some years before it was actually detected. Explain the reason, based on the nature of β^- energy spectra, for postulating its existence. [3]

.....

- (iii) Use the following data to determine the maximum energy, in J, of the β^- particle in the decay of a sample of argon-39. [3]

Mass of argon-39 nucleus = 38.96431 u
 Mass of K nucleus = 38.96370 u

.....

(This question continues on the following page)



(Question B4, part 1 continued)

(c) The half-life of argon-39 is 270 years.

(i) State what quantities you would measure to determine the half-life of argon-39. [2]

.....
.....

(ii) Explain how you would calculate the half-life using the quantities you have stated in (i). [3]

.....
.....
.....
.....

(This question continues on the following page)



(Question B4 continued)

Part 2 Friction

(a) State **two** factors that affect the frictional force between surfaces in contact. [2]

1.

2.

(b) Distinguish between *static friction* and *dynamic (sliding) friction*. [3]

.....
.....
.....
.....
.....

(c) A block of wood of weight 12 N is at rest on a flat, horizontal surface. The minimum horizontal force required to move the block is 7.2 N. Calculate the coefficient of static friction between the block and the surface. [1]

.....
.....
.....

(d) The force of 7.2 N is applied continuously to the block. Explain whether the block will accelerate **or** move with constant speed. [3]

.....
.....
.....
.....
.....

