

1. The time interval between human heartbeats is of the order of

- A. 10^{-2} s.
- B. 10^{-1} s.
- C. 10^0 s.
- D. 10^1 s.

2. The kilowatt-hour is equivalent to approximately

- A. 60 J.
- B. 3.6×10^3 J.
- C. 8.6×10^4 J.
- D. 3.6×10^6 J.

3. The speed of sound v in a gas is related to the pressure P of the gas by the expression

$$v = \sqrt{kP}$$

where k is a constant.

Which variables should be plotted in order to produce a straight-line graph with the slope equal to k ?

- A. v^2 against P^2
- B. v^2 against P
- C. v against P
- D. v against \sqrt{P}

4. A uniform metal bar XY of weight W is hung from a horizontal support at point P by two wires of negligible mass.

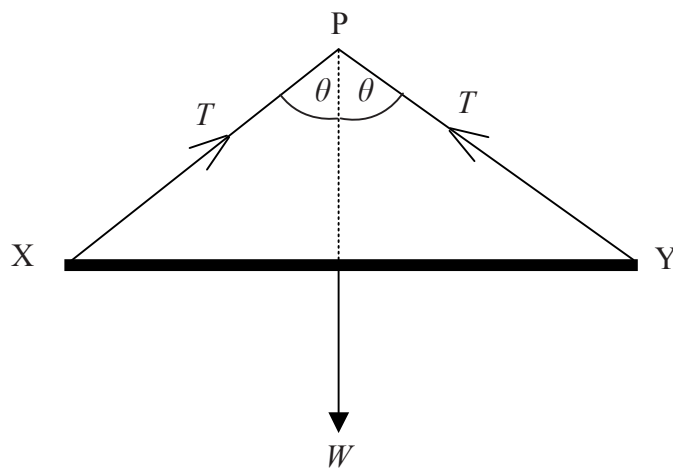

Each wire makes an angle θ with the vertical.

Which of the following is equal to the tension T in one of the wires?

- A. $\frac{W}{\cos \theta}$
- B. $\frac{W}{2 \cos \theta}$
- C. $\frac{W}{\sin \theta}$
- D. $\frac{W}{2 \sin \theta}$

5. The graph shows the variation with time t of the acceleration a of an object.

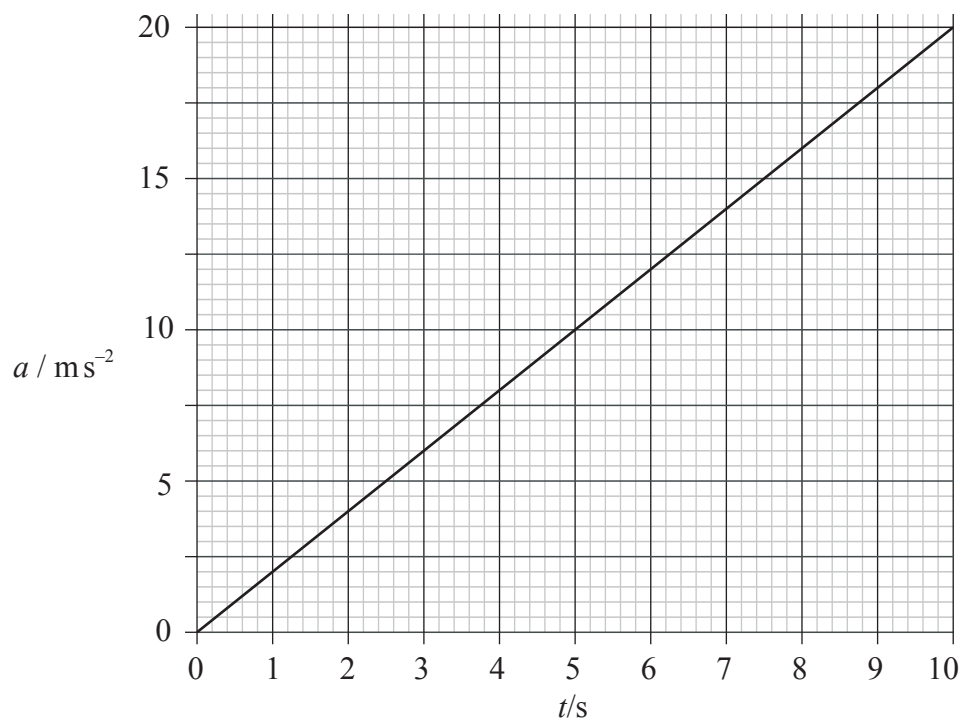

The object is at rest at time $t = 0$.

Which of the following is the velocity of the object at time $t = 6.0 \text{ s}$?

- A. 0.50 ms^{-1} .
- B. 2.0 ms^{-1} .
- C. 36 ms^{-1} .
- D. 72 ms^{-1} .

6. An object is dropped from rest from a point several hundred metres above the surface of the Earth at time $t = 0$. The object strikes the ground at $t = T$ and air resistance is **not** negligible.

Which of the following sketch graphs best shows the variation with time t , of the speed v of the object?

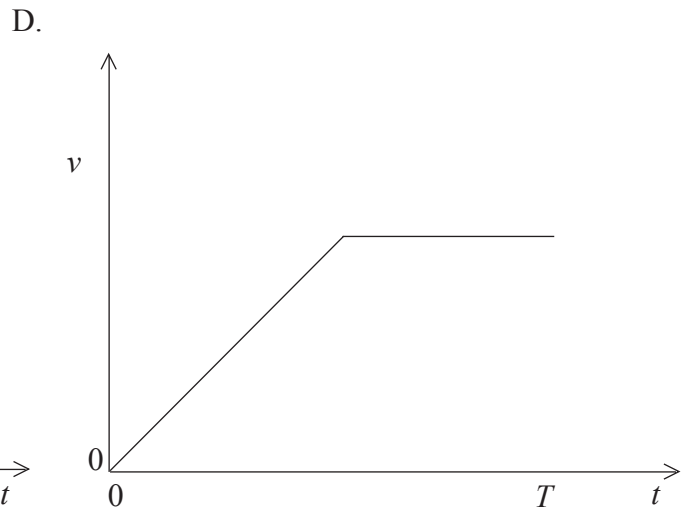
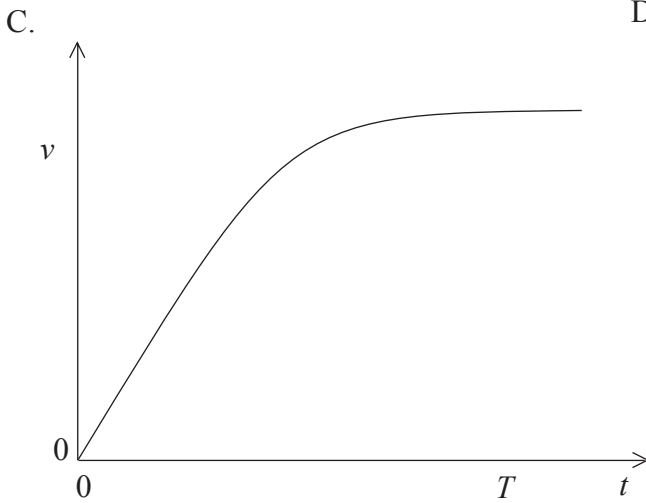
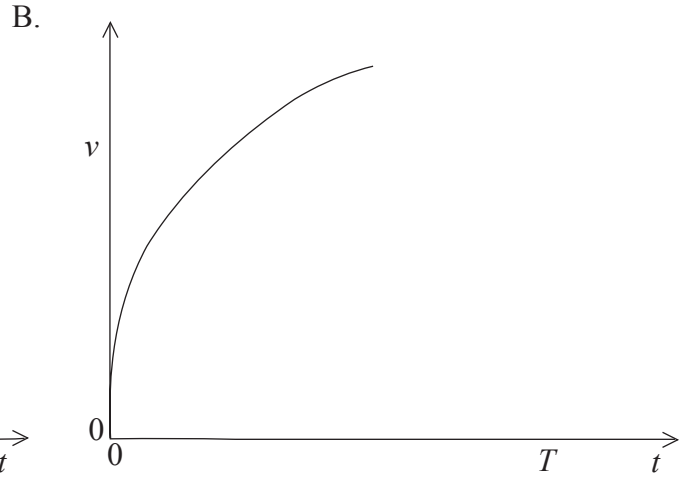
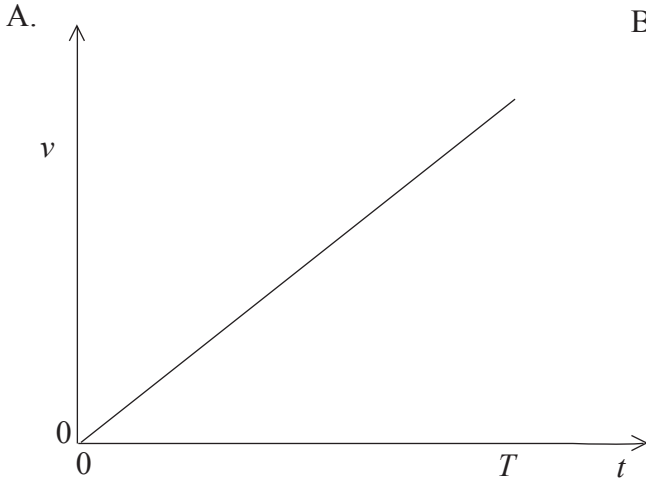

7. Which of the following is a correct definition of average acceleration?

A. $\frac{\text{change in velocity}}{\text{time taken}}$

B. $\frac{\text{velocity}}{\text{time taken}}$

C. $\frac{\text{change in speed}}{\text{time taken}}$

D. $\frac{\text{speed}}{\text{time taken}}$

8. A picture is supported vertically by a wire that is looped over a horizontal light peg P. There is no friction between the wire and the peg.

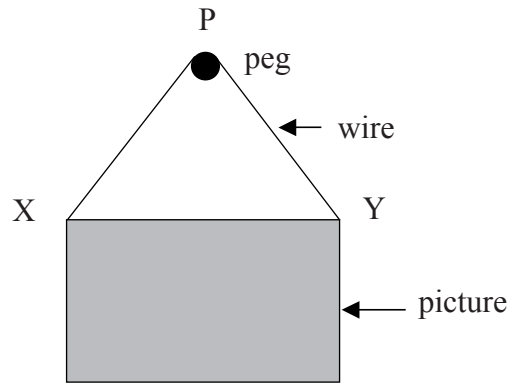

The mass of the picture is uniformly distributed and $PX = PY$.

Which of the following best represents the free body diagram of the forces acting on the peg?

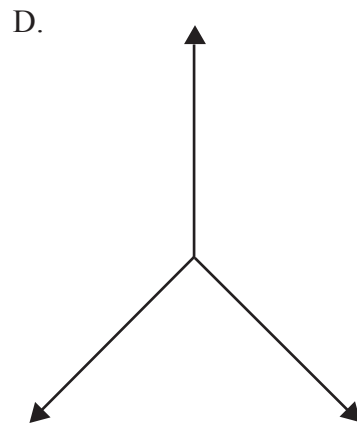
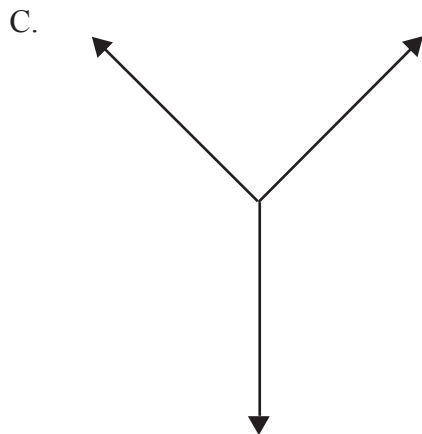
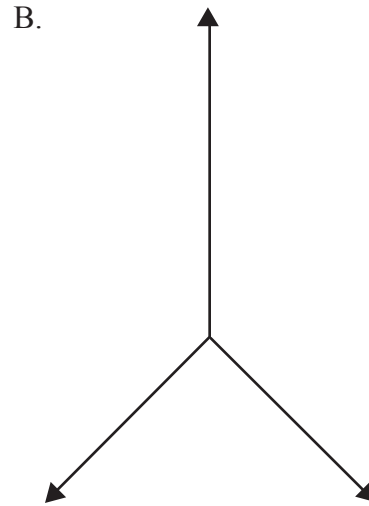
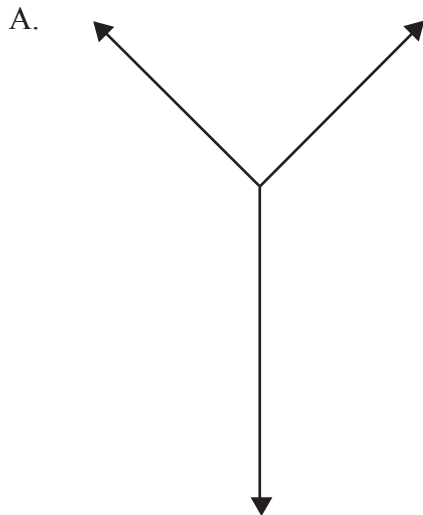

9. All objects at any particular point on the Earth's surface have the same value of free fall acceleration. The reason for this is because the magnitude of the
- A. gravitational force acting on each object is the same.
 - B. gravitational and inertial mass of each object is the same.
 - C. gravitational force acting on any object is proportional only to its gravitational mass.
 - D. gravitational force acting on any object is proportional only to its inertial mass.
10. The net force acting on a body is zero. Which of the following quantities must also have zero magnitude for this body?
- A. Momentum
 - B. Velocity
 - C. Speed
 - D. Acceleration

11. A constant force of magnitude F acts on a body. The graph shows the variation with time t of the momentum p of the body.

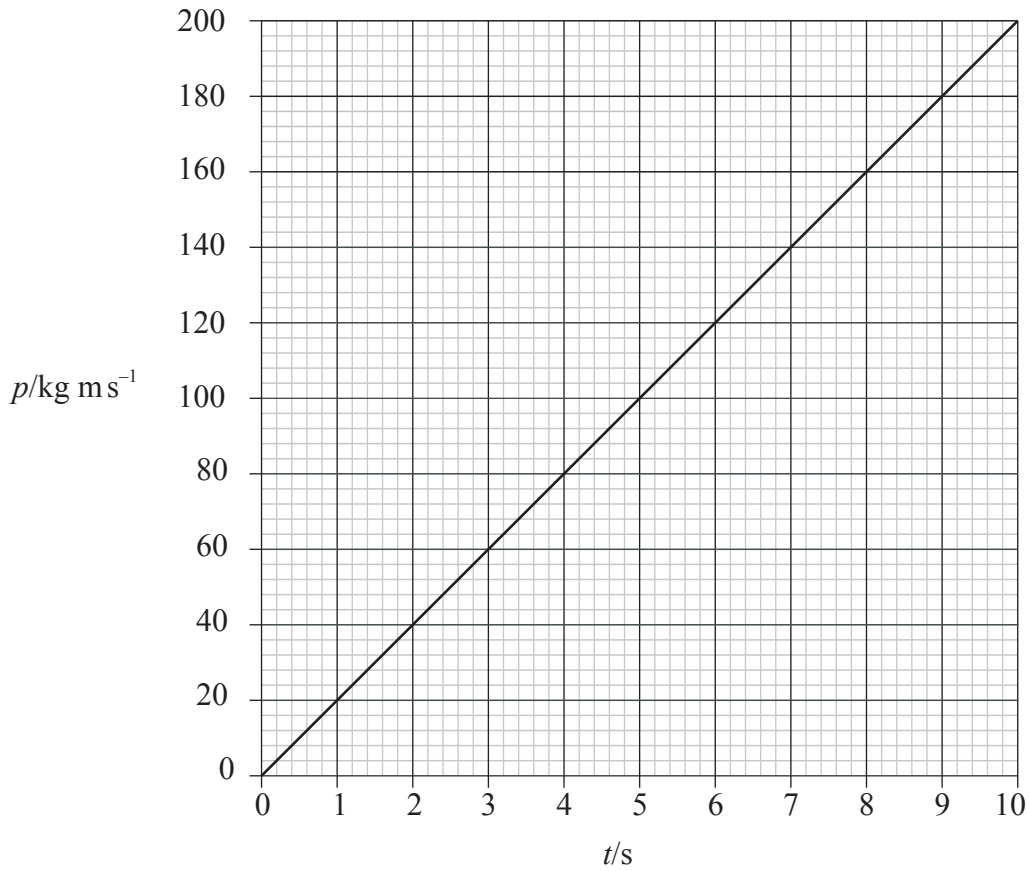

The magnitude of the force F is

- A. 1000 N.
- B. 200 N.
- C. 20 N.
- D. 0.05 N.

12. A block on a frictionless horizontal table is attached by a light, inextensible string to an object P of mass m that hangs vertically as shown below.

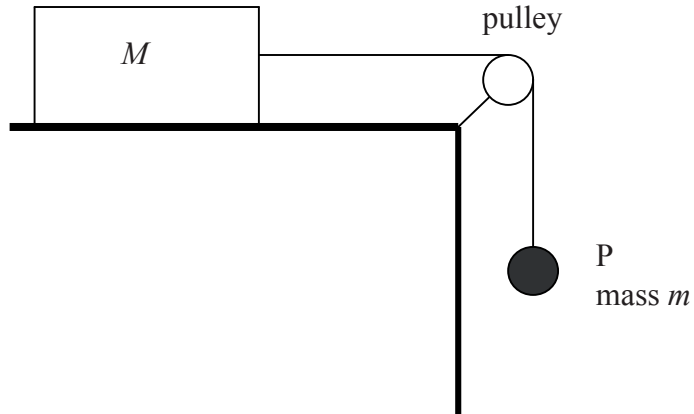

The pulley has zero friction and the acceleration of free fall is g . The acceleration of the block and object P is

- A. g .
 - B. $\frac{m}{M}g$.
 - C. $\frac{m}{m+M}g$.
 - D. $\frac{m+M}{m}g$.
13. Two objects collide inelastically. For this system of two objects
- A. only momentum is conserved.
 - B. only kinetic energy is conserved.
 - C. both momentum and kinetic energy are conserved.
 - D. neither momentum nor kinetic energy are conserved.

14. An object of weight 50 N is dragged up an inclined plane at constant speed, through a vertical height of 12 m. The total work done is 1500 J.

The work done against friction is

- A. 2100 J.
 - B. 1500 J.
 - C. 900 J.
 - D. 50 J.
15. Two objects X and Y are made of the same material. Object X is more massive than object Y. Both objects are at the same temperature.

Which of the following correctly compares the average kinetic energy and also the total energy of the molecules in the objects?

	average kinetic energy of the molecules in X and Y	total energy of the molecules in X and Y
A.	same	greater in X than in Y
B.	same	less in X than in Y
C.	greater in X than in Y	same
D.	less in X than in Y	same

16. An ideal gas is contained in a cylinder by a piston. The volume of the gas is decreased by moving the piston rapidly in the direction shown.

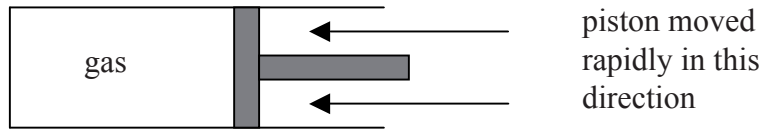

The average speed of the gas molecules is initially increased because the molecules

- A. have a smaller volume in which to move.
 - B. make more collisions in unit time with the cylinder walls and piston.
 - C. have energy transferred to them as they collide with the moving piston.
 - D. make more collisions with each other in unit time.
17. Which of the following correctly describes the changes in the kinetic energy of the molecules and the potential energy of the molecules as a liquid changes phase to a gas?

	kinetic energy of the molecules	potential energy of the molecules
A.	no change	increases
B.	no change	no change
C.	increases	increases
D.	increases	no change

18. The specific heat capacity of an object is defined as the thermal energy required to raise the temperature of
- A. the volume of the object by 1 K.
 - B. unit volume of the object by 1 K.
 - C. the mass of the object by 1K.
 - D. unit mass of the object by 1 K.

19. A wave is travelling through a medium. The diagram shows the variation with time t of the displacement d of a particle of the medium from $t = 0$ to $t = 25$ ms.

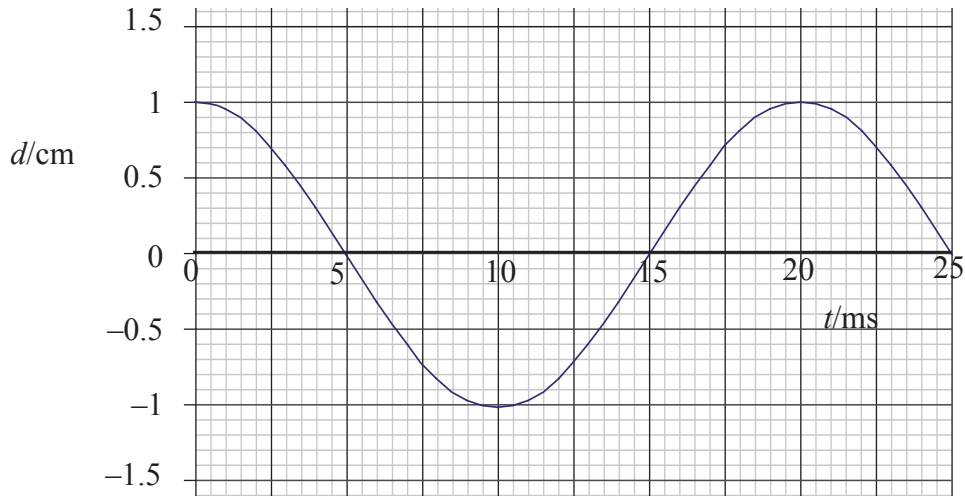

Which of the following correctly gives the frequency and the amplitude of the wave?

	frequency / Hz	amplitude / cm
A.	2.0×10^{-2}	2.0
B.	2.0×10^{-2}	1.0
C.	50	2.0
D.	50	1.0

20. Waves of frequency f travel with speed c in air and enter a medium M of refractive index 1.5. Which of the following correctly gives the frequency and speed of the waves in the medium M?

	frequency	speed
A.	f	$\frac{c}{1.5}$
B.	f	$1.5c$
C.	$1.5f$	c
D.	$\frac{f}{1.5}$	c

21. Pipe X of length 3.0 m is open at both ends. It produces a note of frequency 28 Hz when the air in the pipe vibrates in its fundamental (first harmonic) mode.

Pipe Y is closed at one end and also produces a note of frequency 28 Hz when the air in the pipe vibrates in its fundamental mode. The best estimate for the length of pipe Y is

- A. 12 m.
- B. 6.0 m.
- C. 3.0 m.
- D. 1.5 m.

22. Plane wavefronts are incident on a barrier as shown below.

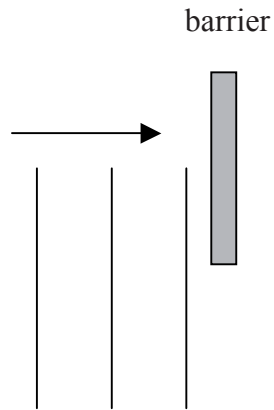

Which of the following best shows the shape of the wavefronts on the other side of the barrier?

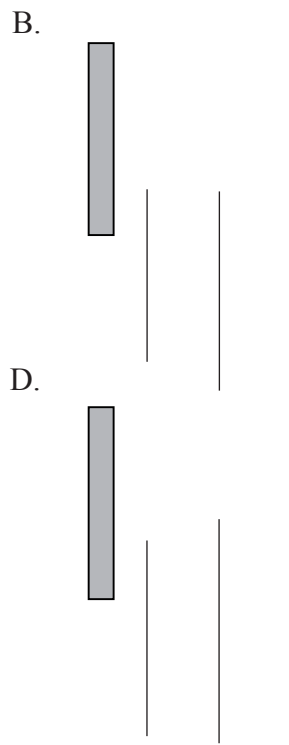
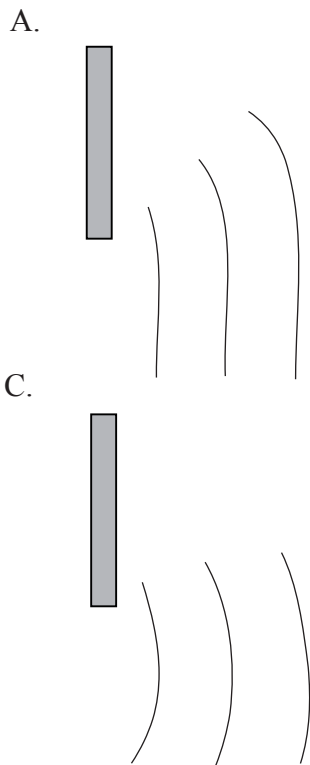

23. An isolated, uncharged metal conductor is brought close to a positively charged insulator.

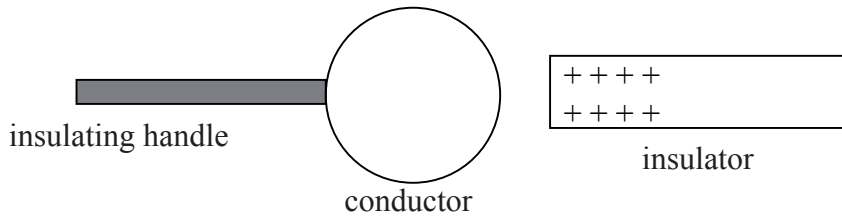

The conductor is earthed (grounded) for a short time and then the insulator is removed.

Which of the following best represents the charge distribution on the surface of the conductor as a result of these actions?

- A. B. C. D.

24. Which of the following is a correct statement of Ohm's law?

- A. The resistance of a conductor is always constant.
- B. The current in a conductor is always proportional to the potential difference across the conductor.
- C. The resistance of a conductor increases with increasing temperature.
- D. The resistance of a conductor is constant only if the temperature of the conductor is constant.

25. An electron and a proton are accelerated from rest through potential differences of the same magnitude. After acceleration the speed of the electron is v_e and the speed of the proton is v_p .

Which of the following is the best estimate for the ratio $\frac{v_p}{v_e}$?

- A. 2000
 - B. $\sqrt{2000}$
 - C. $\frac{1}{\sqrt{2000}}$
 - D. $\frac{1}{2000}$
26. A resistor of resistance 1.0Ω is connected in series with a battery. The current in the circuit is 2.0 A . The resistor is now replaced by a resistor of resistance of 4.0Ω . The current in this circuit is 1.0 A .

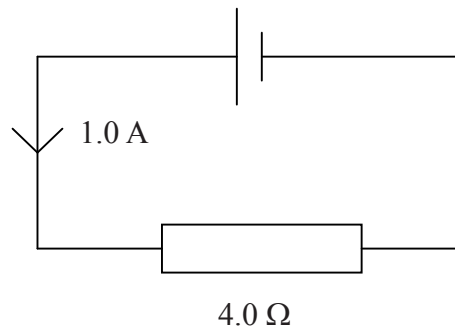
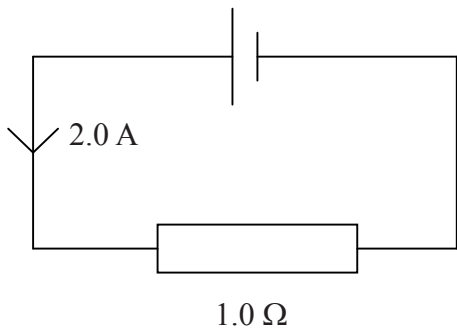

The best estimate for the internal resistance of the battery is

- A. 1.0Ω .
- B. 2.0Ω .
- C. 4.0Ω .
- D. 5.0Ω .

27. The diagram shows part of a long, straight vertical wire in which there is a current I . P is a charged particle at a distance r from the wire. The magnitude of the charge of P is q .

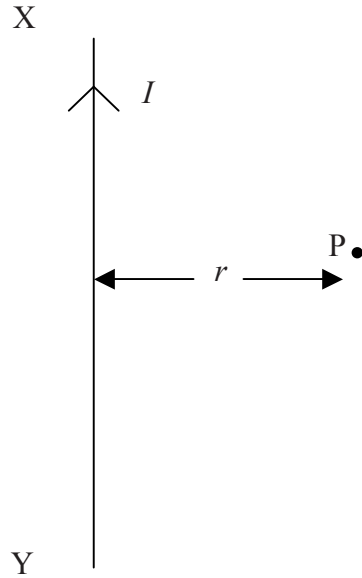

The particle P is moving normally into the plane of the paper with speed v . The magnitude of the force on P due to the magnetic field of the wire is

- A. zero.
 - B. $\frac{\mu_0 I}{2\pi r} qv$.
 - C. $\frac{\mu_0 Iq}{2\pi rv}$.
 - D. $\frac{\mu_0 Iv}{2\pi rq}$.
28. Which of the following provides evidence for the existence of neutrons?
- A. The Geiger-Marsden experiment
 - B. Isotopes
 - C. Natural radioactive decay
 - D. Artificial transmutations of elements

29. A nucleus of uranium 233 (${}^{233}_{92}\text{U}$) undergoes α –decay. Which of the following correctly identifies the number of protons Z and the number of neutrons N of the nucleus produced by this decay?

	Z	N
A.	90	229
B.	90	139
C.	88	231
D.	88	141

30. The equation of a nuclear reaction is shown below.

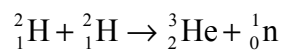

The reaction is an example of

- A. artificial transmutation.
- B. fission.
- C. natural radioactivity.
- D. fusion.