

SECTION A

Answer **all** the questions in the spaces provided.

**A1.** The question is about investigating a fireball caused by an explosion.

When a fire burns within a confined space, the fire can sometimes spread very rapidly in the form of a circular fireball. Knowing the speed with which these fireballs can spread is of great importance to fire-fighters. In order to be able to predict this speed, a series of controlled experiments was carried out in which a known amount of petroleum (petrol) stored in a can was ignited.

The radius  $R$  of the resulting fireball produced by the explosion of some petrol in a can was measured as a function of time  $t$ . The results of the experiment for five different volumes of petroleum are shown plotted below. (Uncertainties in the data are not shown.)

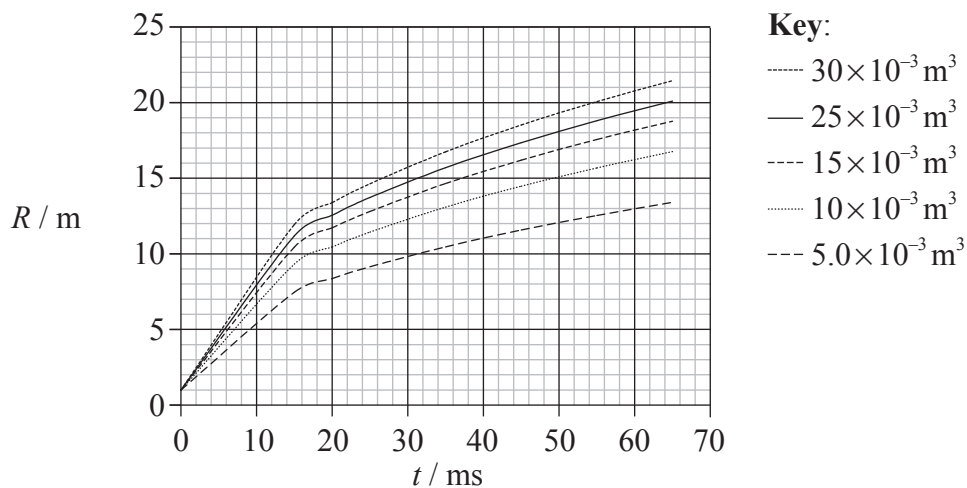

(a) The original hypothesis was that, for a given volume of petrol, the radius  $R$  of the fireball would be directly proportional to the time  $t$  after the explosion. State **two** reasons why the plotted data do not support this hypothesis. [2]

1. ....
- .....
- .....
2. ....
- .....
- .....

(This question continues on the following page)



*(Question A1 continued)*

- (b) The uncertainty in the radius is  $\pm 0.5$  m. The addition of error bars to the data points would show that there is in fact a systematic error in the plotted data. Suggest **one** reason for this systematic error. [2]

.....

.....

.....

.....

*(This question continues on the following page)*



(Question A1 continued)

- (c) It is known that the energy released in the explosion is proportional to the initial volume of petrol. A hypothesis made by the experimenters is that, at a given time, the radius of the fireball is proportional to the energy  $E$  released by the explosion. In order to test this hypothesis, the radius  $R$  of the fireball 20 ms after the explosion was plotted against the initial volume  $V$  of petrol causing the fireball. The resulting graph is shown below.

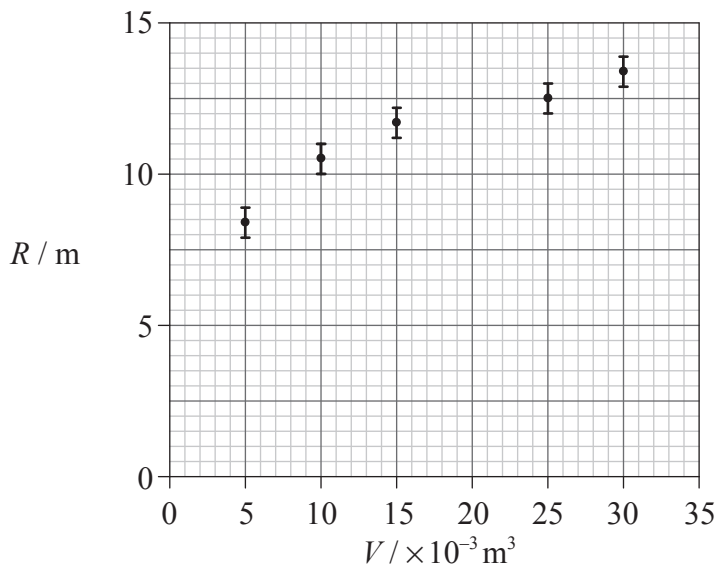

The uncertainties in  $R$  have been included. The uncertainty in the volume of petrol is negligible.

- (i) Describe how the data for the above graph are obtained from the graph in (a). [1]

.....  
.....

- (ii) Draw the line of best-fit for the data points. [2]

- (iii) Explain whether the plotted data together with the error bars support the hypothesis that  $R$  is proportional to  $V$ . [2]

.....  
.....  
.....  
.....  
.....

(This question continues on the following page)



*(Question A1 continued)*

- (d) Analysis shows that the relation between the radius  $R$ , energy  $E$  released and time  $t$  is in fact given by

$$R^5 = Et^2.$$

Use data from the graph in (c) to deduce that the energy liberated by the combustion of  $1.0 \times 10^{-3} \text{ m}^3$  of petrol is about 30 MJ.

[4]

.....  
.....  
.....  
.....  
.....



**A2.** This question is about electric circuits.

(a) (i) Define e.m.f. and state Ohm's law. [2]

e.m.f.: .....

.....

Ohm's law: .....

.....

(ii) The graph below shows the  $I$ - $V$  characteristic of a particular electrical component.

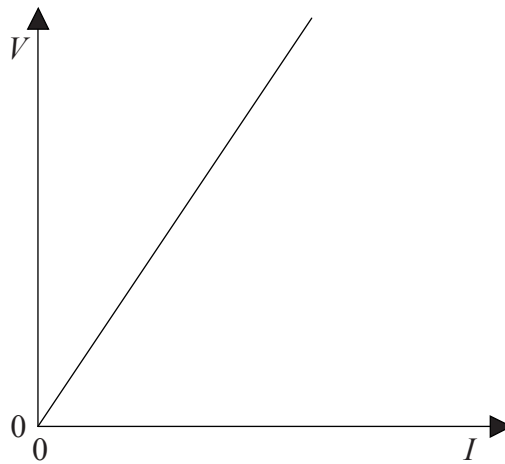

State how the resistance of the component is determined from the graph. [1]

.....

.....

*(This question continues on the following page)*



(Question A2 continued)

- (b) In the circuit below an electrical device (load) is connected in series with a cell of e.m.f. 2.5 V and internal resistance  $r$ . The current  $I$  in the circuit is 0.10 A.

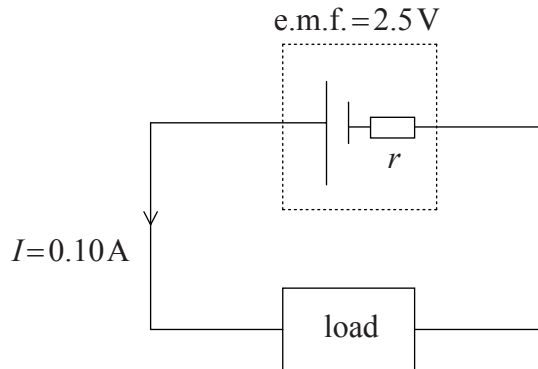

The power dissipated in the load is 0.23 W.

Calculate

- (i) the total power of the cell. [1]

.....  
.....

- (ii) the resistance of the load. [2]

.....  
.....  
.....  
.....

- (iii) the internal resistance  $r$  of the cell. [2]

.....  
.....  
.....  
.....

(This question continues on the following page)



(Question A2 continued)

(c) A second identical cell is connected into the circuit in (b) as shown below.

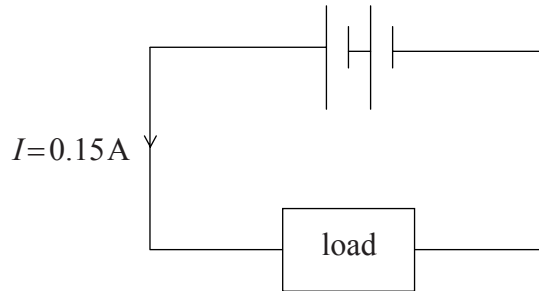

The current in this circuit is 0.15 A. Deduce that the load is a non-ohmic device.

[4]

.....

.....

.....

.....

.....

.....



Blank page



**SECTION B**

*This section consists of three questions: B1, B2 and B3. Answer **one** question.*

**B1.** This question is about Newton’s laws of motion, the dynamics of a model helicopter and the engine that powers it.

(a) Explain how Newton’s third law leads to the concept of conservation of momentum in the collision between two objects in an isolated system. [4]

.....

.....

.....

.....

.....

.....

.....

.....

.....

.....

(b) The diagram illustrates a model helicopter that is hovering in a stationary position.

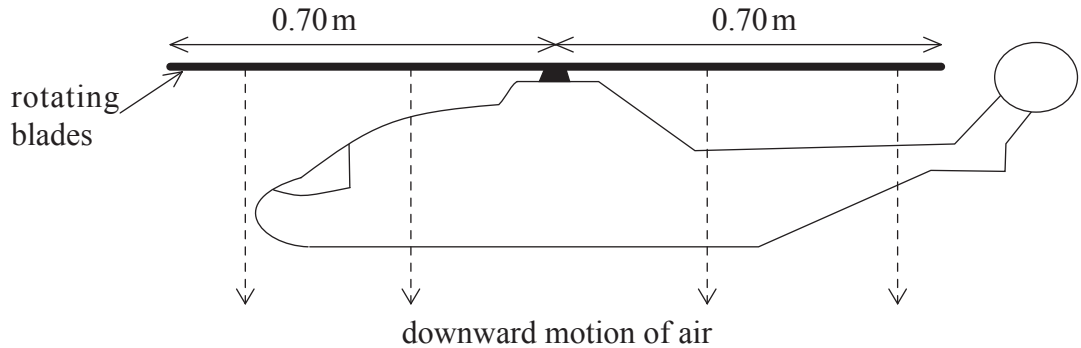

The rotating blades of the helicopter force a column of air to move downwards. Explain how this may enable the helicopter to remain stationary. [3]

.....

.....

.....

.....

.....

.....

*(This question continues on the following page)*



*(Question B1 continued)*

- (c) The length of each blade of the helicopter in (b) is 0.70 m. Deduce that the area that the blades sweep out as they rotate is  $1.5 \text{ m}^2$ . (Area of a circle =  $\pi r^2$ ) [1]

.....

.....

- (d) For the hovering helicopter in (b), it is assumed that all the air beneath the blades is pushed vertically downwards with the same speed of  $4.0 \text{ m s}^{-1}$ . No other air is disturbed.

The density of the air is  $1.2 \text{ kg m}^{-3}$ .

Calculate, for the air moved downwards by the rotating blades,

- (i) the mass per second. [2]

.....

.....

.....

.....

- (ii) the rate of change of momentum. [1]

.....

.....

- (e) State the magnitude of the force that the air beneath the blades exerts on the blades. [1]

.....

- (f) Calculate the mass of the helicopter and its load. [2]

.....

.....

.....

.....

*(This question continues on the following page)*



*(Question B1 continued)*

- (g) In order to move forward, the helicopter blades are made to incline at an angle  $\theta$  to the horizontal as shown schematically below.

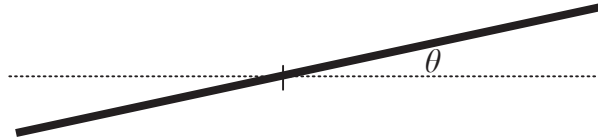

While moving forward, the helicopter does not move vertically up or down. In the space provided below draw a free body force diagram that shows the forces acting on the helicopter blades at the moment that the helicopter starts to move forward. On your diagram, label the angle  $\theta$ .

[4]

*(This question continues on the following page)*



*(Question B1 continued)*

- (h) Use your diagram in (g) opposite to explain why a forward force  $F$  now acts on the helicopter and deduce that the initial acceleration  $a$  of the helicopter is given by

$$a = g \tan \theta$$

where  $g$  is the acceleration of free fall.

[5]

.....

.....

.....

.....

.....

.....

.....

.....

.....

.....

- (i) Suggest why, even though the forward force  $F$  does not change, the acceleration of the helicopter will decrease to zero as it moves forward.

[2]

.....

.....

.....

.....



Blank page

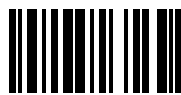

**B2.** This question is in **two** parts. **Part 1** is about stationary (standing) waves and resonance. **Part 2** is about radioactive decay.

**Part 1** Stationary (standing) waves and resonance

(a) State **two** ways in which a standing wave differs from a continuous wave. [2]

- 1. ....  
.....
- 2. ....  
.....

(b) State the principle of superposition as applied to waves. [2]

.....  
.....  
.....  
.....

*(This question continues on the following page)*



*(Question B2, part 1 continued)*

- (c) A stretched string is fixed at one end. The other end is vibrated continuously to produce a wave along the string. The wave is reflected at the fixed end and as a result a standing wave is set up in the string.

The diagram below shows the displacement of the string at time  $t=0$ . The dotted line shows the equilibrium position of the string.

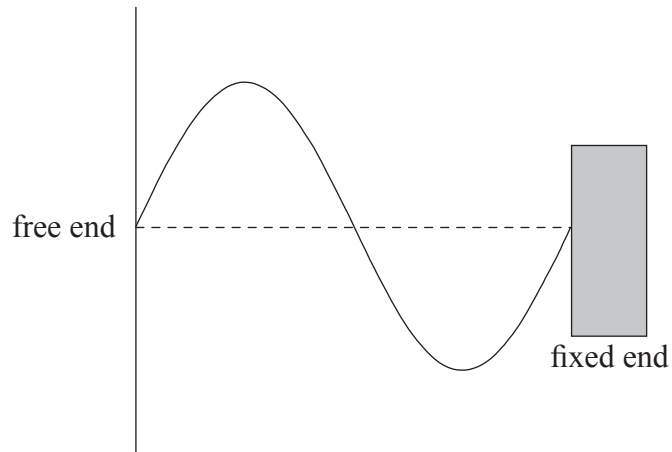

*(This question continues on the following page)*



(Question B2, part 1 continued)

- (i) The period of oscillation of the string is  $T$ . On the diagrams below, draw sketches of the displacement of the string at time  $t = \frac{T}{4}$  and at time  $t = \frac{T}{2}$ . [2]

$$t = \frac{T}{4}$$

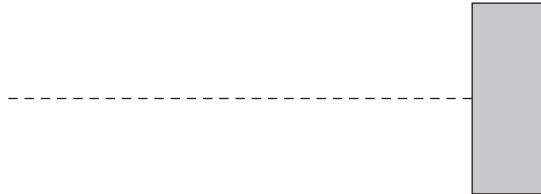

$$t = \frac{T}{2}$$



- (ii) Use your sketches in (i) to explain why the wave in the string appears to be stationary. [2]

.....

.....

.....

.....

(This question continues on the following page)



(Question B2, part 1 continued)

(d) Stationary waves are often associated with the phenomenon of resonance.

(i) Describe what is meant by *resonance*. [2]

.....  
.....  
.....  
.....

(ii) On 19 September 1985 an earthquake occurred in Mexico City. Many buildings that were about 80 m tall collapsed whereas buildings that were taller or shorter than this remained undamaged. Use the data below to suggest a reason for this. [3]

period of oscillation of an 80 m tall building	= 2.0 s
speed of earthquake waves	= $6.0 \times 10^3 \text{ m s}^{-1}$
average wavelength of the waves	= $1.2 \times 10^4 \text{ m}$

.....  
.....  
.....  
.....  
.....

(This question continues on the following page)



(Question B2 continued)

**Part 2** Radioactive decay

(a) The nucleon number (mass number) of a stable isotope of argon is 36 and of a radioactive isotope of argon is 39.

(i) State what is meant by a *nucleon*. [1]

.....  
.....

(ii) Explain, in terms of the number of nucleons and the forces between them, why argon-36 is stable and argon-39 is radioactive. [4]

.....  
.....  
.....  
.....  
.....

(b) A particular nucleus of argon-39 undergoes the decay shown by the nuclear reaction equation below.

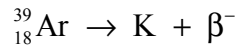

(i) State the proton (atomic) number and the nucleon (mass) number of the potassium (K) nucleus. [2]

Proton number: .....

Nucleon number: .....

(ii) Use the following data to determine the maximum energy, in J, of the  $\beta^{-}$  particle in the decay of a sample of argon-39. [3]

Mass of argon-39 nucleus = 38.96431 u

Mass of K nucleus = 38.96370 u

.....  
.....  
.....  
.....

(This question continues on the following page)



(Question B2, part 2 continued)

- (c) The graph below shows the variation with time  $t$  of the activity  $A$  of a sample of argon-39.

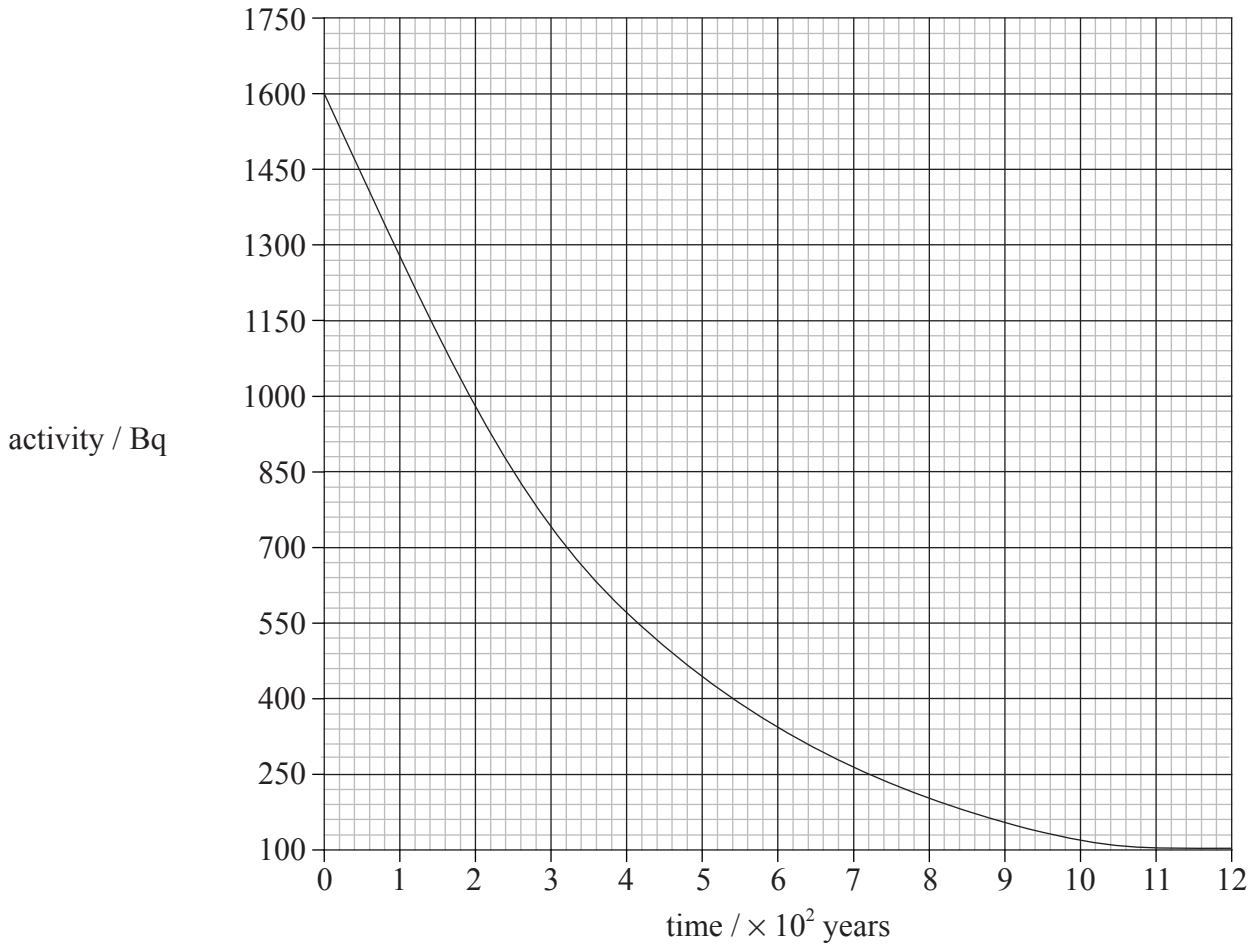

Use the graph to determine the half-life of argon-39. Explain your reasoning.

[2]

.....

.....

.....

.....



**B3.** This question is in **two** parts. **Part 1** is about gases and liquids. **Part 2** is about electrical conduction and the force on a conductor in a magnetic field.

**Part 1** Gases and liquids

(a) Describe **two** differences, in terms of molecular structure, between a gas and a liquid. [2]

- 1. ....  
.....
- 2. ....  
.....

(b) The temperature of an ideal gas is a measure of the average kinetic energy of the molecules of the gas. Explain why the **average** kinetic energy is specified. [2]

.....  
.....  
.....  
.....

(c) Define *heat (thermal) capacity*. [1]

.....  
.....

*(This question continues on the following page)*



(Question B3, part 1 continued)

- (d) Water is heated at a constant rate in a container that has negligible heat capacity. The container is thermally insulated from the surroundings.

The sketch-graph below shows the variation with time of the temperature of the water.

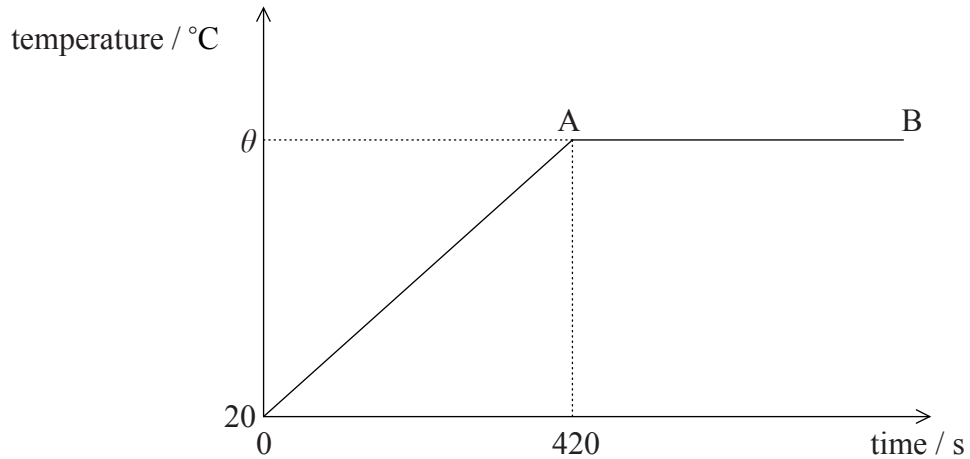

The following data are available:

- initial mass of water = 0.40 kg
- initial temp of water = 20 °C
- rate at which water is heated = 300 W
- specific heat capacity of water =  $4.2 \times 10^3 \text{ J kg}^{-1} \text{ °C}^{-1}$

- (i) State the reason why the temperature is constant in the region A→B. [1]

.....

.....

- (ii) Calculate the temperature  $\theta$  at which the water starts to boil. [5]

.....

.....

.....

.....

.....

.....

.....

.....

.....

.....

(This question continues on the following page)



*(Question B3, part 1 continued)*

- (e) All the water is boiled away  $3.0 \times 10^3$  s after it first starts to boil. Determine a value for the specific latent heat  $L$  of vaporisation of water. [2]

.....

.....

.....

.....

*(This question continues on the following page)*



(Question B3 continued)

**Part 2** Electrical conduction and the force on a conductor in a magnetic field

- (a) The diagram below shows a copper rod inside which an electric field of strength  $E$  is maintained by connecting the copper rod in series with a cell. (Connections to the cell are not shown.)

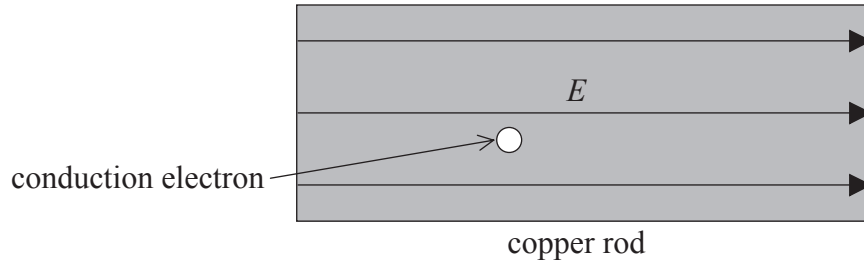

- (i) On the diagram, draw an arrow to show the direction of the force on the conduction electron shown. Label this arrow with the letter  $F$ . [1]

- (ii) Describe how the electric field enables the conduction electrons to have a drift velocity in a direction along the copper rod. [3]

.....

.....

.....

.....

.....

(This question continues on the following page)



(Question B3, part 2 continued)

- (b) A copper rod is placed on two parallel, horizontal conducting rails PQ and SR as shown below. The conducting rails are connected to a battery and switch X.

The rails and the copper rod are in a region of uniform magnetic field of strength  $B$ . The magnetic field is normal to the plane of the conducting rods as shown in the diagram below.

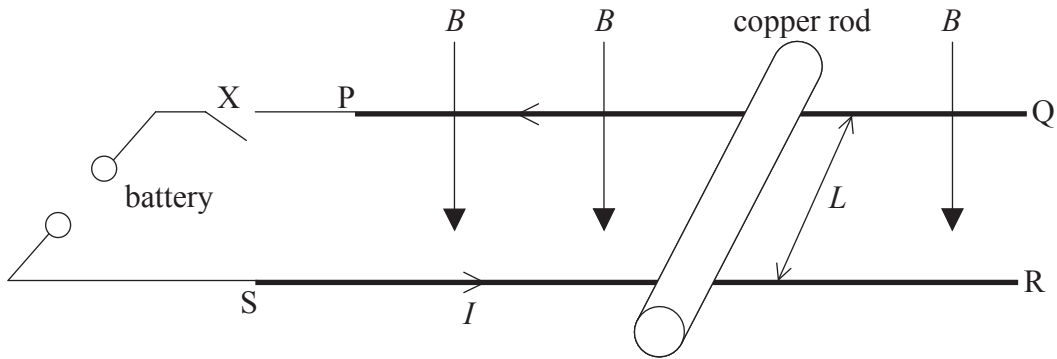

The length of the copper rod between the rails is  $L$ . The mass of the copper rod is  $M$ . Friction between the copper rod and the rails is negligible.

The switch X is now closed and the current in the copper rod is  $I$  and in the direction shown in the diagram.

- (i) On the diagram, draw an arrow to show the direction of the force  $F$  on the copper rod. [1]
- (ii) Derive an expression in terms of  $B$ ,  $L$ ,  $M$  and  $I$ , for the initial acceleration  $a$  of the copper rod. [2]

.....

.....

.....

(This question continues on the following page)



(Question B3, part 2 continued)

(c) The copper rod in (b) eventually moves with constant speed  $v$ . When moving at this constant speed, the power supplied by the battery is equal to rate at which work is done by the force  $F$ .

(i) Deduce that the power  $P$  supplied by the force  $F$  acting on the copper rod when it is moving at constant speed  $v$  is given by the expression

$$P = Fv. \quad [2]$$

.....  
.....  
.....  
.....

(ii) Use the expression in (i) and the data below to determine the speed  $v$ . [3]

e.m.f. of the battery = 0.80 V  
length of copper rod  $L$  = 0.60 m  
field strength  $B$  = 0.25 T

.....  
.....  
.....  
.....  
.....

