

SECTION A

Answer **all** the questions in the spaces provided.

A1. A hot object may be cooled by blowing air past it. This cooling process is known as forced convection. In order to investigate forced convection, hot oil was placed in a metal can. The can was placed on an insulating block and air was blown past the can, as shown below.

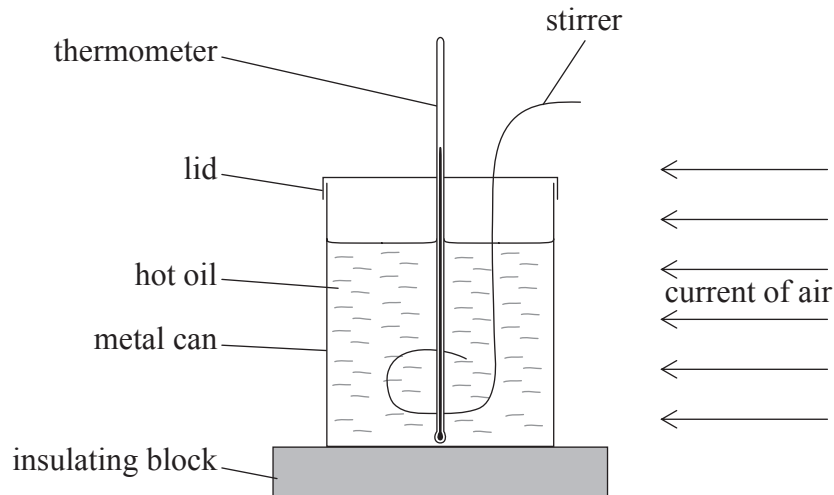

(This question continues on the following page)

(Question A1 continued)

The hot oil was stirred continuously and its temperature was taken every minute as it cooled. The graph below shows the variation with time of the temperature of the cooling oil.

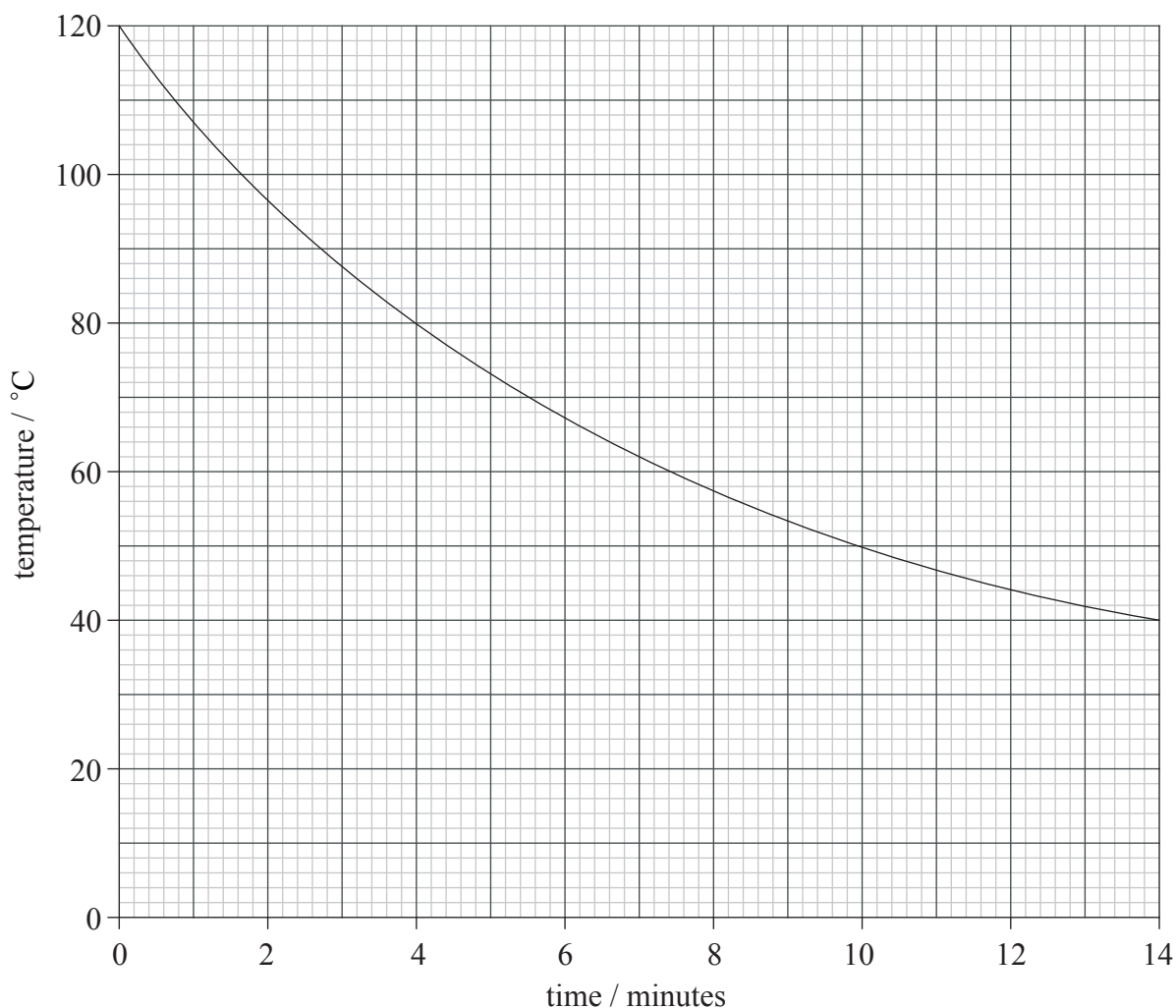

It is thought that the rate R of decrease of temperature depends on the temperature difference between the oil and its surroundings (the excess temperature θ_E). The temperature of the surroundings was 26°C .

(a) On the graph above,

(i) draw a straight-line parallel to the time axis to represent the temperature of the surroundings. [1]

(ii) by drawing a suitable tangent, calculate the rate of decrease of temperature, in $^\circ\text{C s}^{-1}$, for an excess temperature of 50 Celsius degrees ($^\circ\text{C}$). [4]

.....

.....

.....

.....

(This question continues on the following page)



(Question A1 continued)

- (b) In order to investigate the variation with R of θ_E , a graph of R against θ_E is plotted. The graph below shows four plotted data points. Uncertainties in the points are not included.

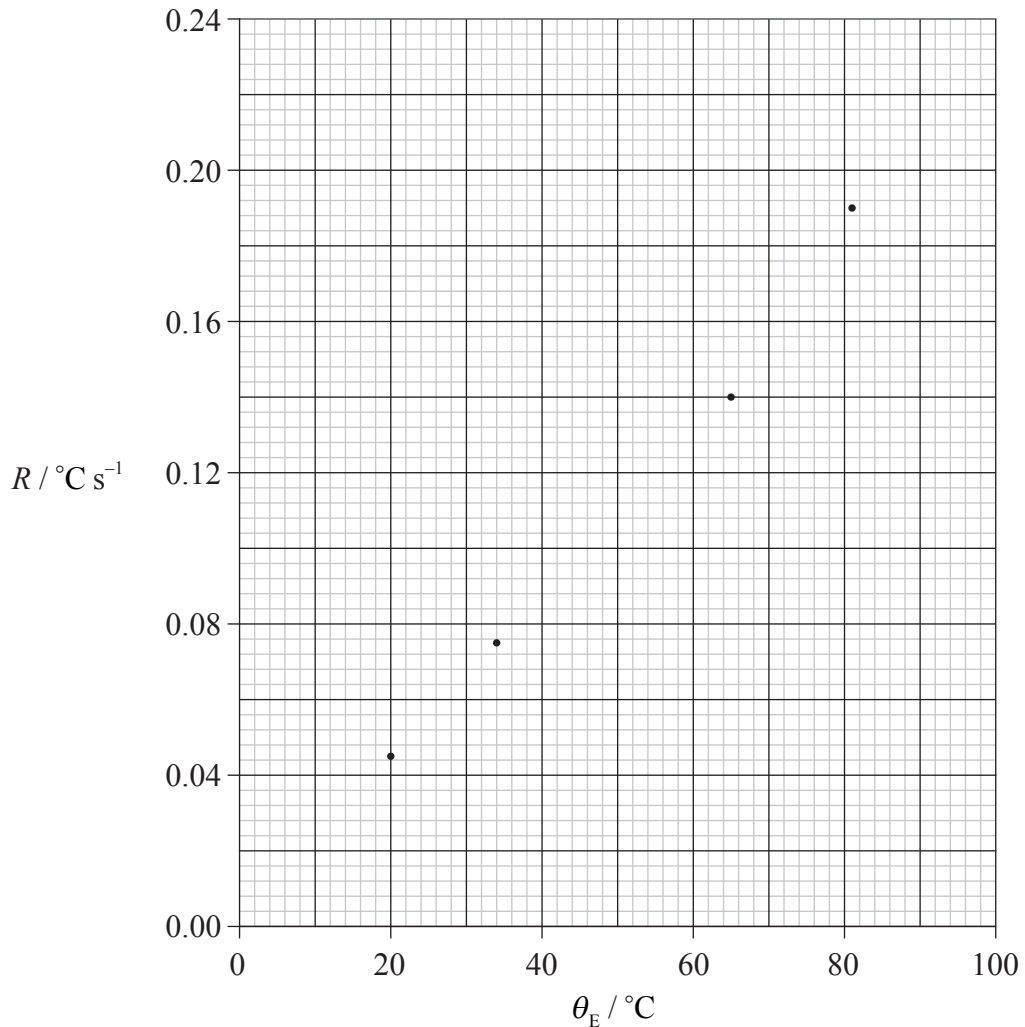

- (i) Using your answer to (a)(ii), plot the data point corresponding to $\theta_E = 50^\circ\text{C}$. [1]
- (ii) The uncertainty in the measurement of R at each excess temperature is $\pm 10\%$. On the graph, draw error bars to represent the uncertainties in R at excess temperatures of 20°C and 81°C . [2]

(This question continues on the following page)



(Question A1 continued)

- (c) (i) Explain why the graph in (b) supports the conclusion that the excess temperature θ_E is related to the rate of cooling R by the expression

$$R = k\theta_E,$$

where k is a constant. [3]

.....

.....

.....

.....

- (ii) At high excess temperatures, the equation in (i) is thought to become invalid. Discuss whether the graph in (b) provides any evidence for this suggestion. [2]

.....

.....

.....

- (d) In a second experiment, the data is analysed by plotting a graph of $\lg R$ against $\lg \theta_E$. (\lg is the logarithm to the base 10.)

- (i) On the axes below, draw a sketch graph to show the line that would be obtained. (Note that this is a sketch graph. No data points or values on the axes are required.) [1]

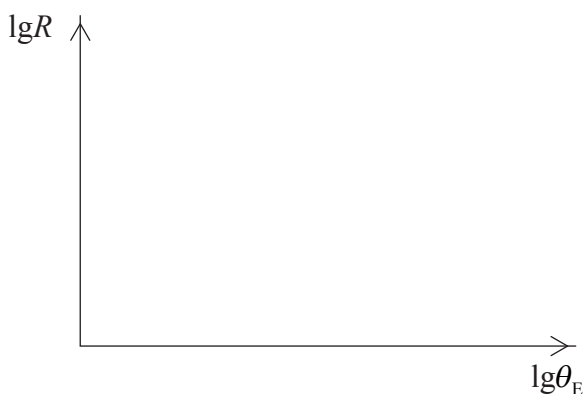

- (ii) Assuming the expression in (c)(i) is correct, state the gradient of the line of the graph. Also, explain how the value of k is obtained. [2]

.....

.....

.....



A2. This question is about nuclear and particle physics.

(a) Draw a schematic diagram of one type of mass spectrometer. [3]

(b) Describe, using your diagram in (a), how the existence of isotopes may be determined. [2]

.....
.....
.....
.....
.....

(c) Nucleons are made up of quarks and belong to a class of particles called hadrons. There is a strong interaction and also a weak interaction between quarks. State the name of the exchange particle associated with

(i) the strong interaction between quarks. [1]

.....

(ii) the weak interaction between quarks. [1]

.....

(iii) the strong interaction between hadrons. [1]

.....



A3. This question is about temperature, internal energy and thermodynamics.

- (a) Two solid objects undergo the same temperature change. A student states that the change in internal energy of the two objects would be the same.

Briefly discuss this statement.

[3]

.....
.....
.....
.....
.....

- (b) (i) State, in terms of entropy change, the second law of thermodynamics.

[1]

.....
.....

- (ii) When an ice crystal forms from liquid water, the entropy of the water decreases.

By reference to the second law, discuss the entropy change.

[3]

.....
.....
.....
.....

(This question continues on the following page)



(Question A3 continued)

- (c) The diagram below shows the relation between the pressure P and the volume V of an ideal gas for one cycle ABCDA of a Carnot cycle.

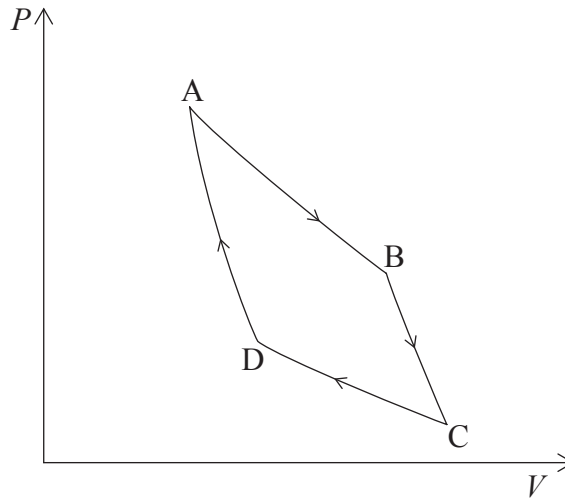

For the change from B to C,

- (i) state the name of this change. [1]

.....

- (ii) discuss, by reference to the first law of thermodynamics, the transfers of energy. [3]

.....
.....
.....
.....



Blank page



SECTION B

*This section consists of four questions: B1, B2, B3 and B4. Answer **two** questions.*

B1. This question is in **two** parts. **Part 1** is about linear motion and **Part 2** is about collisions.

Part 1 Linear motion

(a) Define the term *acceleration*. [2]

.....
.....

(b) An object has an initial speed u and an acceleration a . After time t , its speed is v and it has moved through a distance s .

The motion of the object may be summarised by the equations

$$v = u + at,$$
$$s = \frac{1}{2}(v + u)t.$$

(i) State the assumption made in these equations about the acceleration a . [1]

.....

(ii) Derive, using these equations, an expression for v in terms of u , s and a . [2]

.....
.....
.....
.....

(This question continues on the following page)



(Question B1, part 1 continued)

- (c) The shutter speed of a camera is the time that the film is exposed to light. In order to determine the shutter speed of a camera, a metal ball is held at rest at the zero mark of a vertical scale, as shown below. The ball is released. The shutter of a camera is opened as the ball falls.

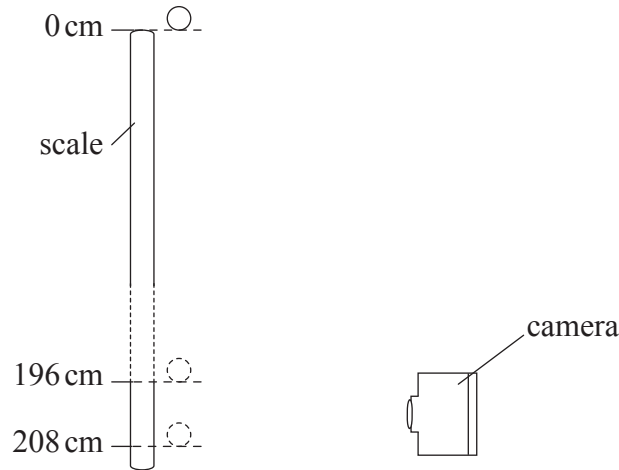

The photograph of the ball shows that the shutter opened as the ball reached the 196 cm mark on the scale and closed as it reached the 208 cm mark. Air resistance is negligible and the acceleration of free fall is 9.81 ms^{-2} .

- (i) Calculate the time for the ball to fall from rest to the 196 cm mark. [2]

.....

- (ii) Determine the time for which the shutter was open. That is, the time for the ball to fall from the 196 cm mark to the 208 cm mark. [2]

.....

- (iii) Explain why a more accurate value for the shutter speed can be obtained if the ball is allowed to fall a greater distance before the shutter is opened. [3]

.....

(This question continues on the following page)



(Question B1 continued)

Part 2 Collisions

A large metal ball is hung from a crane by means of a cable of length 5.8 m as shown below.

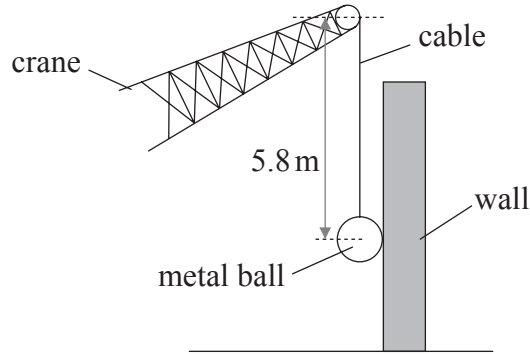

In order to knock down a wall, the metal ball of mass 350 kg is pulled away from the wall and then released. The crane does not move. The graph below shows the variation with time t of the speed v of the ball after release.

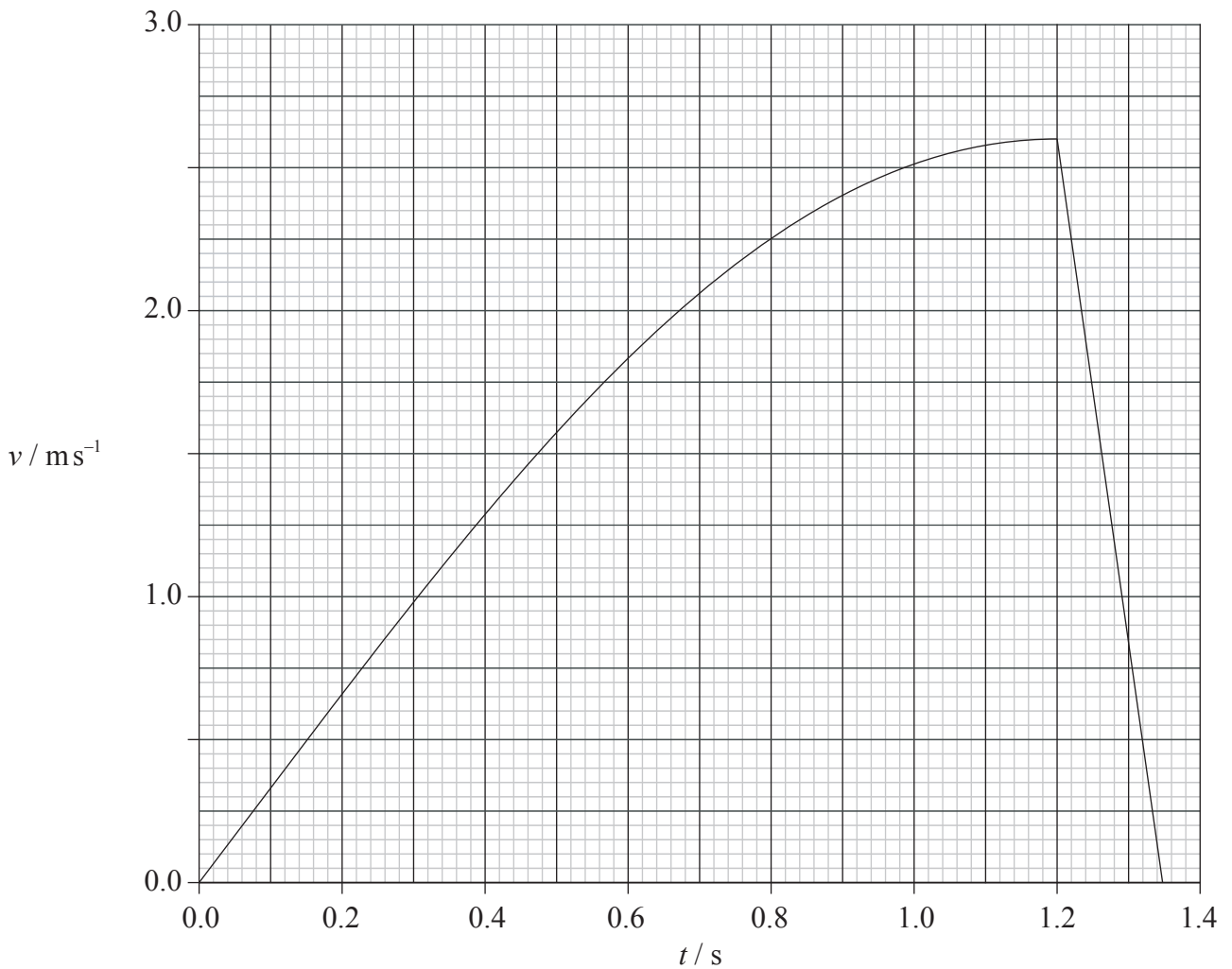

(This question continues on the following page)



(Question B1, part 2 continued)

The ball makes contact with the wall when the cable from the crane is vertical.

(a) For the ball just before it hits the wall,

(i) state why the tension in the cable is not equal to the weight of the ball. [1]

.....
.....

(ii) by reference to the graph, estimate the tension in the cable. The acceleration of free fall is 9.8 m s^{-2} . [3]

.....
.....
.....
.....

(b) Use the graph to determine the distance moved by the ball after coming into contact with the wall. [2]

.....
.....
.....
.....

(This question continues on the following page)



(Question B1, part 2 continued)

(c) For the collision between the ball and the wall, calculate

(i) the total change in momentum of the ball. [2]

.....
.....
.....

(ii) the average force exerted by the ball on the wall. [2]

.....
.....
.....

(d) (i) State the law of conservation of momentum. [2]

.....
.....
.....

(ii) The metal ball has lost momentum. Discuss whether the law applies to this situation. [2]

.....
.....
.....
.....

(e) During the impact of the ball with the wall, 12% of the total kinetic energy of the ball is converted into thermal energy in the ball. The metal of the ball has specific heat capacity $450 \text{ J kg}^{-1} \text{ K}^{-1}$. Determine the average rise in temperature of the ball as a result of colliding with the wall. [4]

.....
.....
.....
.....



B2. This question is in **two** parts. **Part 1** is about gravitation. **Part 2** is about electromagnetic induction.

Part 1 Gravitation

The diagram below illustrates the planet Saturn.

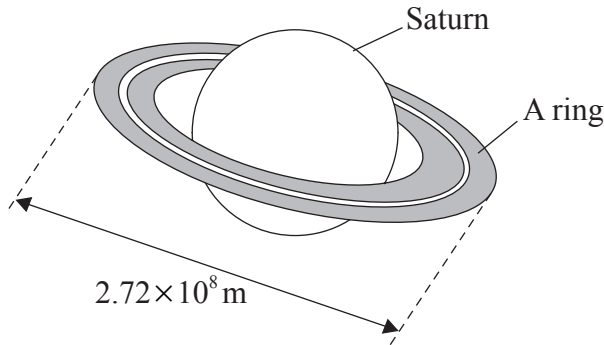

Saturn has several rings, each of which consists of many small particles that orbit the planet. Saturn may be considered to be a sphere with its mass M concentrated at its centre.

- (a) Deduce that, for a particle in one ring moving in a circular orbit of radius R , the linear speed v of the particle in its orbit is given by the expression

$$GM = Rv^2.$$

Explain your reasoning.

[2]

.....

.....

.....

.....

.....

- (b) One ring, the A ring, has an outer diameter of $2.72 \times 10^8 \text{ m}$. The mass of Saturn is $5.69 \times 10^{26} \text{ kg}$. A particle orbits on the outer edge of this ring. Determine the time for the particle to complete one orbit of Saturn.

[3]

.....

.....

.....

.....

(This question continues on the following page)



(Question B2, part 1 continued)

(c) Another particle of mass m is orbiting at a distance r from the centre of Saturn.

(i) State a formula, in terms of G , M , m and r for the gravitational potential energy E_p of the particle. [1]

.....

(ii) The gravitational potential energy of this particle decreases. Suggest and explain the change, if any, in the linear speed of the particle. [2]

.....
.....
.....

(d) Explain the concept of *escape speed*. [2]

.....
.....
.....

(e) A planet has radius R and the acceleration of free fall at its surface is g . The planet may be considered to be a sphere with its mass concentrated at its centre.

Deduce that the escape speed v_{es} is given by the expression

$$v_{es} = \sqrt{(2gR)}.$$

Explain your working and state **one** assumption that is made in the derivation. [4]

.....
.....
.....
.....
.....

(This question continues on the following page)



(Question B2, part 1 continued)

- (f) Calculate the escape speed for a spherical planet of radius 1.7×10^3 km having an acceleration of free fall at its surface of 1.6 m s^{-2} . [2]

.....

.....

.....

- (g) The mean kinetic energy E_k , in joule, of helium-4 atoms at thermodynamic temperature T is given by the expression

$$E_k = 2.1 \times 10^{-23} T.$$

Determine the surface temperature of the planet such that helium-4 atoms on the surface of the planet have the escape speed calculated in (f). [2]

.....

.....

.....

- (h) Suggest **one** reason why, at temperatures below that calculated in (g), helium will escape from the planet. [1]

.....

.....

(This question continues on the following page)



(Question B2 continued)

Part 2 Electromagnetic induction

A small circular coil of area of cross-section $1.7 \times 10^{-4} \text{ m}^2$ contains 250 turns of wire. The plane of the coil is placed parallel to, and a distance x from, the pole-piece of a magnet, as shown below.

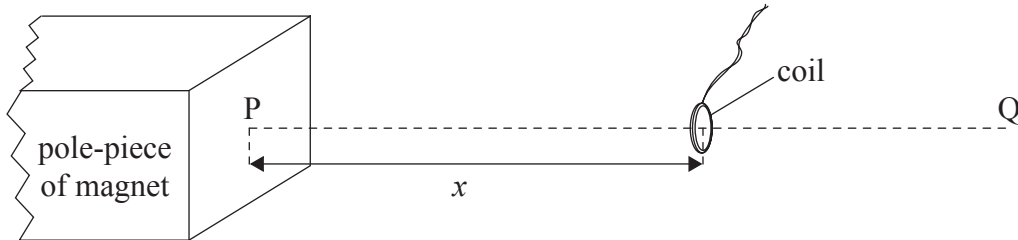

PQ is a line that is normal to the pole-piece. The variation with distance x along line PQ of the mean magnetic field strength B in the coil is shown below.

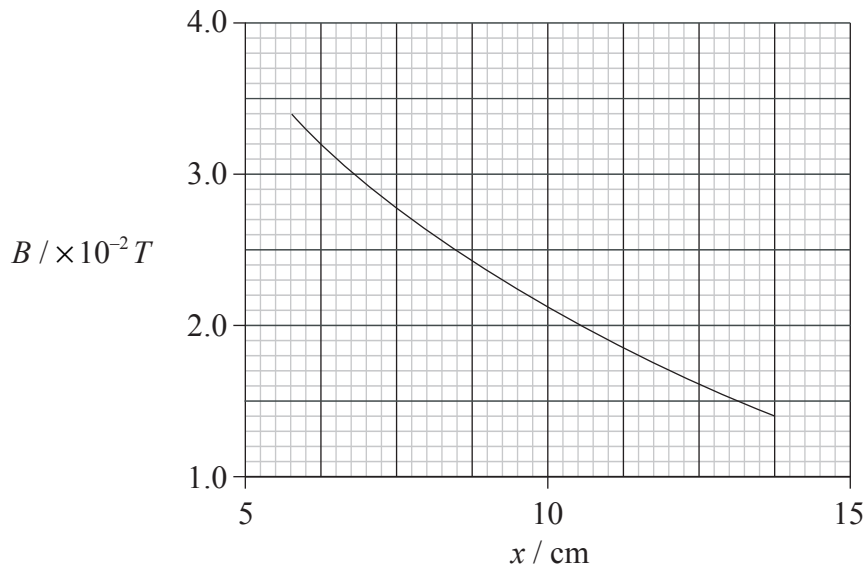

(a) For the coil situated a distance 6.0 cm from the pole-piece of the magnet,

(i) state the average magnetic field strength in the coil. [1]

.....

(ii) calculate the flux linkage through the coil. [2]

.....

(This question continues on the following page)



(Question B2, part 2 continued)

(b) The coil is moved along PQ so that the distance x changes from 6.0 cm to 12.0 cm in a time of 0.35 s.

(i) Deduce that the **change** in magnetic flux linkage through the coil is approximately 7×10^{-4} Wb. [2]

.....
.....
.....

(ii) State Faraday's law of electromagnetic induction and hence calculate the mean e.m.f. induced in the coil. [2]

.....
.....
.....
.....

(c) (i) State Lenz's law. [1]

.....
.....

(ii) Use Lenz's law to explain why work has to be done to move the coil along the line PQ. [3]

.....
.....
.....
.....



B3. This question is about wave phenomena and the particle nature of light.

Travelling waves

- (a) Graph 1 below shows the variation with time t of the displacement d of a travelling (progressive) wave. Graph 2 shows the variation with distance x along the same wave of its displacement d .

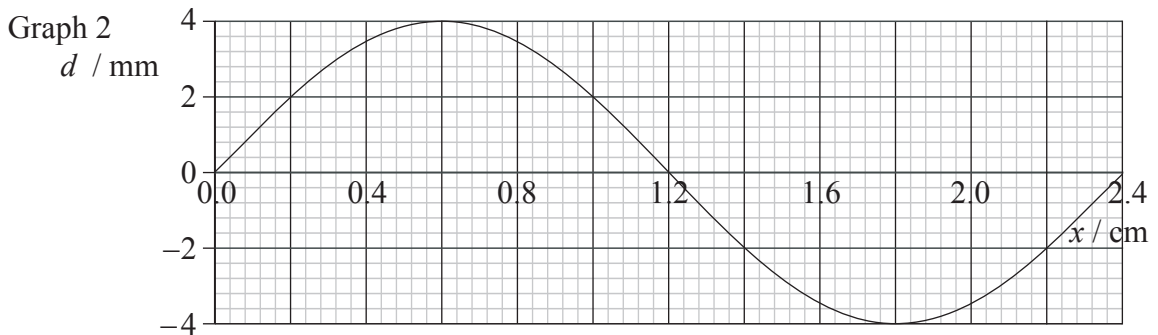
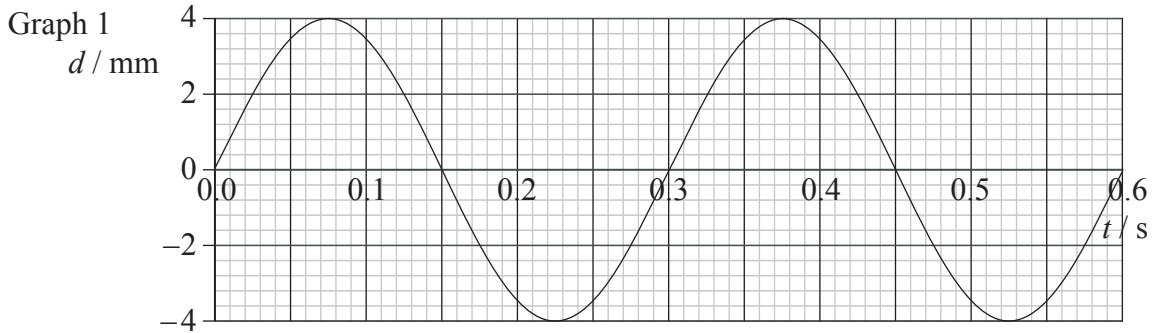

- (i) State what is meant by a *travelling* wave. [1]

.....

.....

- (ii) Use the graphs to determine the amplitude, wavelength, frequency and speed of the wave.

Amplitude: [1]

Wavelength: [1]

Frequency: [1]

Speed: [1]

.....

(This question continues on the following page)



(Question B3 continued)

Refraction of waves

- (b) The diagram below shows plane wavefronts incident on a boundary between two media A and B.

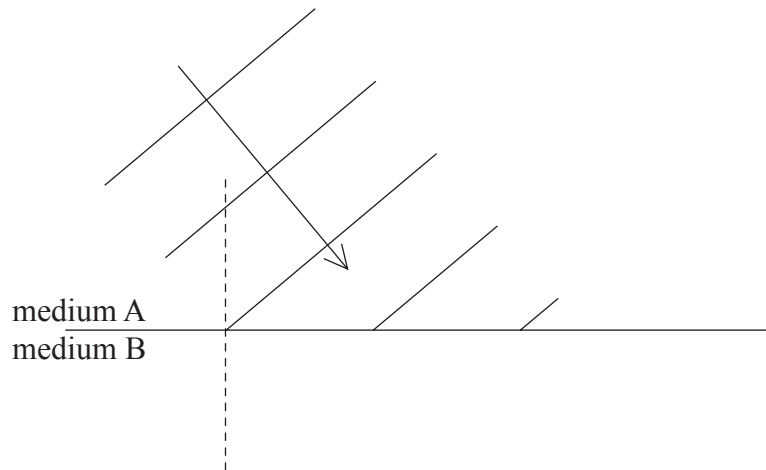

The ratio $\frac{\text{refractive index of medium B}}{\text{refractive index of medium A}}$ is 1.4.

The angle between an incident wavefront and the normal to the boundary is 50° .

- (i) Calculate the angle between a refracted wavefront and the normal to the boundary. [3]

.....

.....

.....

.....

- (ii) On the diagram above, construct **three** wavefronts to show the refraction of the wave at the boundary. [3]

(This question continues on the following page)



(Question B3 continued)

Interference of waves

(c) State **two** conditions necessary to produce observable interference between light from two sources. [2]

1.

2.

(d) A Young's double slit experiment for red light is set up as shown below.

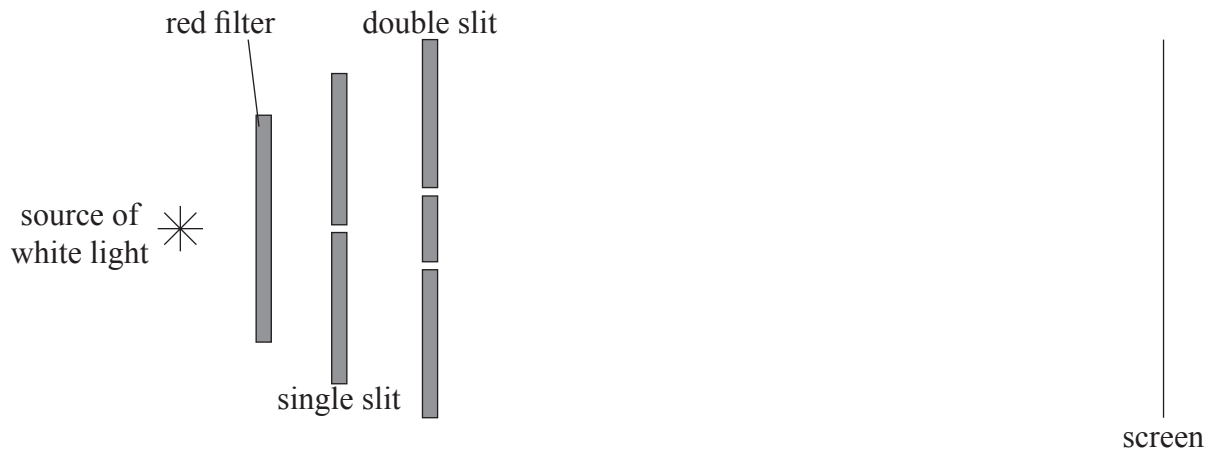

(not to scale)

An interference pattern of light and dark fringes is observed on the screen.

(i) The red filter is now replaced by a blue filter. State and explain the change in appearance, other than change of colour, of the fringes on the screen. [2]

.....
.....
.....

(ii) The filter in (i) is removed. State and explain the appearance of the central maximum fringe and also of fringes that are away from this central position. [4]

.....
.....
.....
.....
.....

(This question continues on the following page)



(Question B3 continued)

Particle nature of light

(e) The photo-electric effect cannot be explained on the basis of a wave theory of electromagnetic radiation. State **two** experimental observations, other than the existence of a threshold frequency, that led to this conclusion. [2]

- 1.
- 2.

(f) Monochromatic light is incident on a metal surface in a photo-cell as shown below.

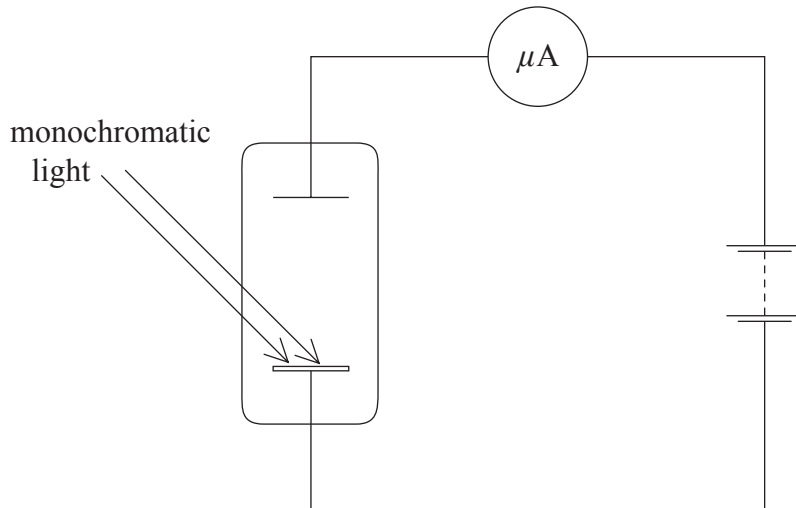

The metal surface has work function 2.4 eV and the threshold wavelength for light incident on the surface is λ_s . The current in the photo-cell is measured using a microammeter.

Calculate the threshold wavelength λ_s . [3]

-
-
-
-

(This question continues on the following page)



(Question B3 continued)

- (g) Light of wavelength $\frac{1}{2} \lambda_s$ and intensity I is incident on the metal surface in (f). (Intensity is the light power incident per unit area.) The current in the photo-cell is i_p .

State and explain the effect on the current i_p in the photo-cell for light incident on the surface

- (i) of wavelength $\frac{1}{2} \lambda_s$ and intensity $2I$. [3]

.....
.....
.....

- (ii) of wavelength less than $\frac{1}{2} \lambda_s$ and intensity I . [3]

.....
.....
.....



B4. This question is in **two** parts. **Part 1** is about electricity. **Part 2** is about radioactivity.

Part 1 Electricity

Static electricity

(a) By reference to the movement of charge in a metal and in plastic, explain the electrical properties of conductors and insulators. [3]

.....
.....
.....
.....

(b) A gold-leaf electroscope is positively charged.

(i) Explain why the electroscope has an electric potential with respect to Earth. [2]

.....
.....
.....

(ii) Outline why there is no electric field inside the metal cap of the electroscope. [2]

.....
.....
.....

(iii) A student touches the metal cap of the electroscope. Describe the movement of charge that occurs. [2]

.....
.....
.....

(This question continues on the following page)



(Question B4, part 1 continued)

Current electricity

- (c) In order to investigate the variation of the current I in a variable resistor with the potential difference V across it, a student set up the following circuit.

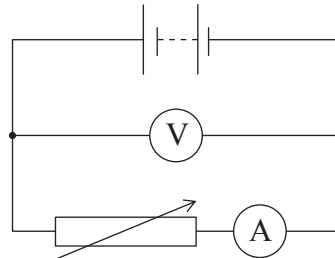

The variation of the current I with V is shown below.

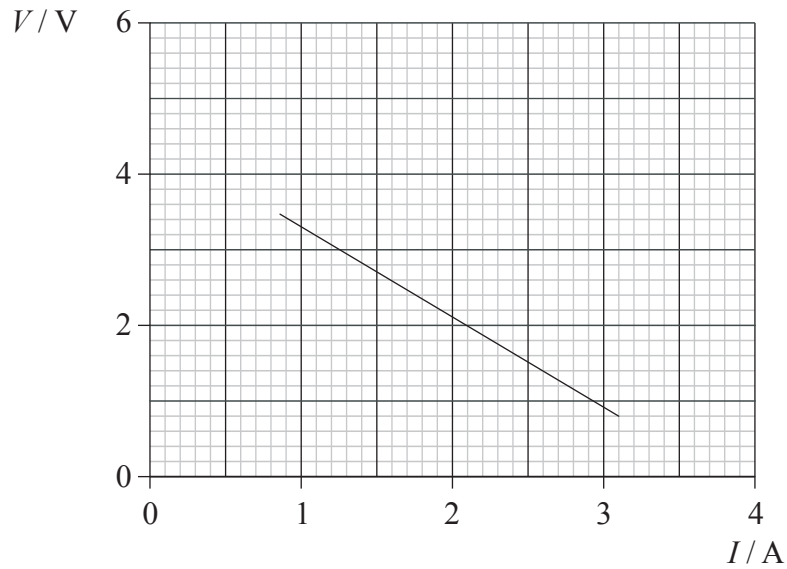

Use the graph to deduce that, for the battery,

- (i) its e.m.f. is 4.5 V. [2]

.....
.....
.....

- (ii) its internal resistance is 1.2Ω . [2]

.....
.....
.....

(This question continues on the following page)



(Question B4, part 1 continued)

- (d) The battery in (c) is to be used as the power source for an electrical device. The device is rated as 0.8 V, 1.5 A.

Complete the circuit below to show how the battery may be connected so that the device operates normally. Calculate the value of any other component you may use. [4]

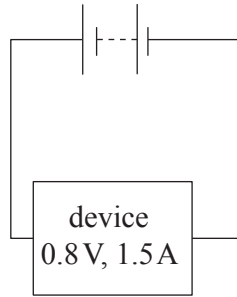

.....

.....

.....

(This question continues on the following page)



(Question B4, part 1 continued)

- (e) An electric heater contains a number of similar heating elements, connected as shown to a supply of V volts. The switches S_1 and S_2 are shown “open”.

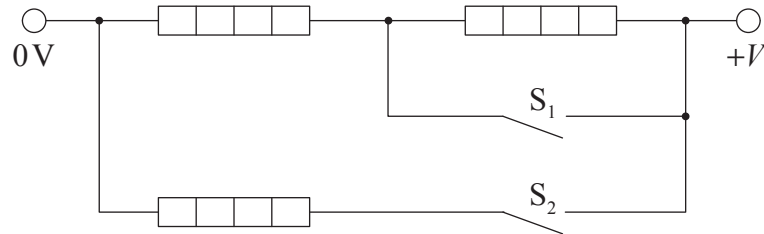

Each heating element dissipates power P when connected to a supply of V volts. The resistance of each element may be considered to be constant.

Complete the table below to give the total power dissipated, in terms of P , for the switches in the positions indicated. [3]

Switch S_1	Switch S_2	Total power
closed	closed	
closed	open	
open	open	

(This question continues on the following page)

(Question B4 continued)

Part 2 Radioactivity

(a) State what is meant by the term

(i) *isotopes.* [2]

.....
.....
.....

(ii) *decay constant.* [1]

.....
.....

(b) Complete the nuclear reaction equation for the decay process indicated below. [2]

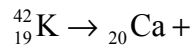

(This question continues on the following page)



(Question B4, part 2 continued)

(c) One isotope of potassium is potassium-42 (${}^{42}_{19}\text{K}$). Nuclei of this isotope undergo radioactive decay with a decay constant 0.0555 hour^{-1} to form nuclei of calcium. At time $t=0$, a sample of potassium-42 contains N_0 nuclei.

(i) On the graph below, label the x -axis with values to show the variation with time t /hours of the number N of potassium nuclei in the sample. [2]

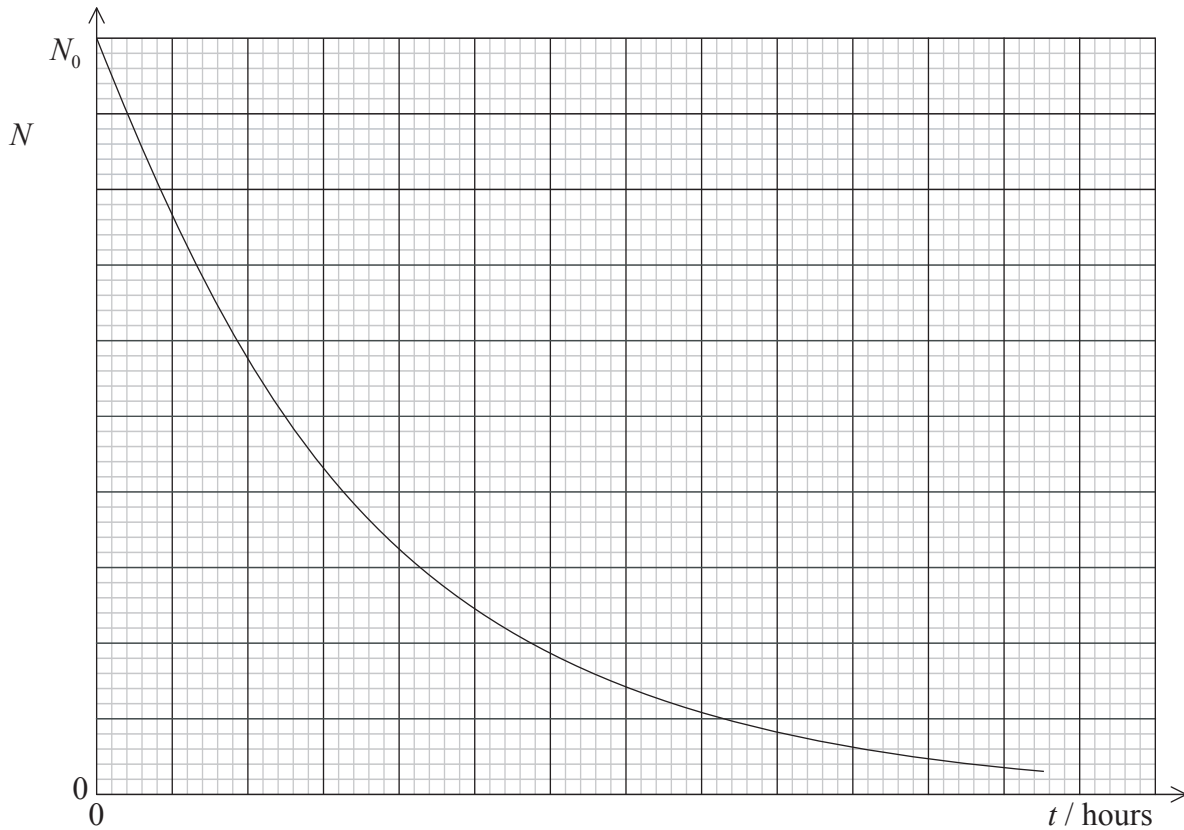

(ii) The isotope of calcium formed in this decay is stable. On the graph above, draw a line to show the variation with time t of the number of calcium nuclei in the sample. [1]

(d) Use the graph, or otherwise, to determine the time at which the ratio

$$\frac{\text{number of calcium nuclei in sample}}{\text{number of potassium-42 nuclei in sample}}$$

is equal to 4.0. [2]

.....
.....
.....

