

1. Which **one** of the following quantities is a vector?
 - A. Work
 - B. Temperature
 - C. Electric field
 - D. Pressure

2. The volume of the Earth is approximately 10^{12} km^3 and the volume of a grain of sand is approximately 1 mm^3 . The order of magnitude of the number of grains of sand that can fit in the volume of the Earth is
 - A. 10^{12} .
 - B. 10^{18} .
 - C. 10^{24} .
 - D. 10^{30} .

3. Three forces of magnitude $F_1 = 3.0 \text{ N}$, $F_2 = 4.0 \text{ N}$ and $F_3 = 6.0 \text{ N}$ act at a point. The point is in equilibrium. The magnitude of the resultant of F_1 and F_2 is
 - A. 1.0 N.
 - B. 5.0 N.
 - C. 6.0 N.
 - D. 7.0 N.

4. The graph below shows the variation with time t of the displacement d of a body moving along a straight-line.

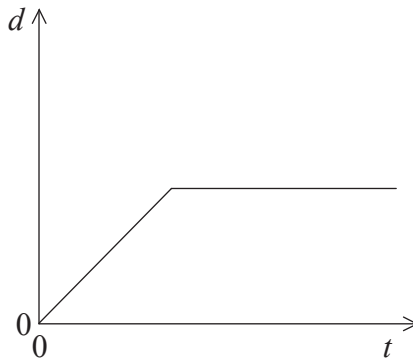

Which graph best represents the variation with time t of the velocity v of this body?

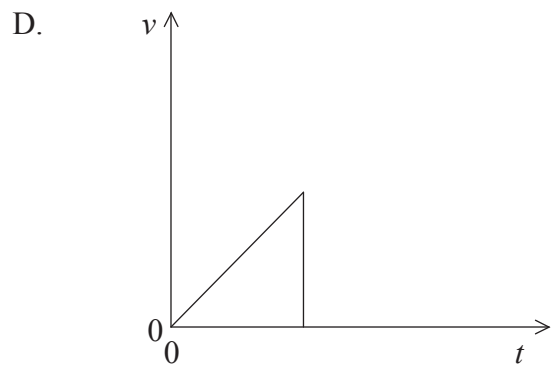
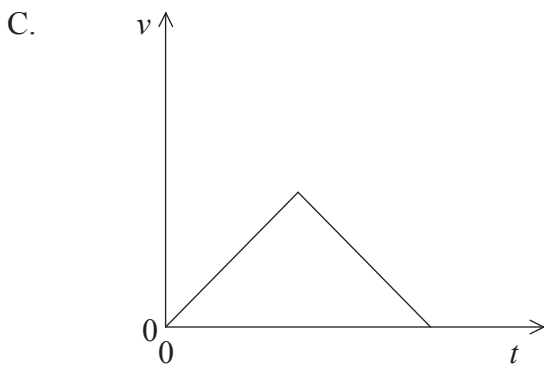
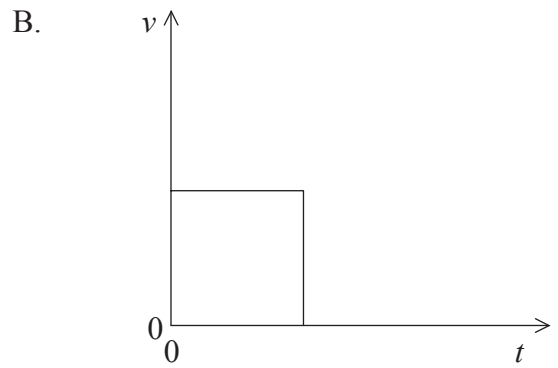
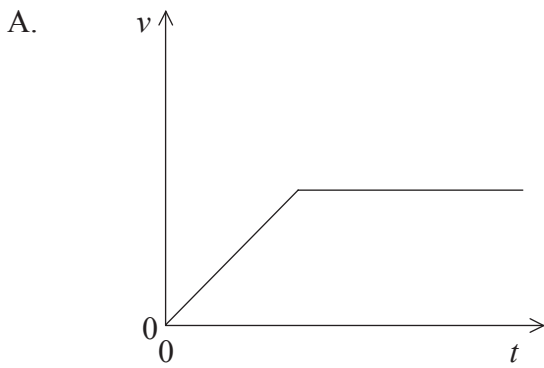

5. A body starting from rest moves along a straight-line under the action of a constant force. After travelling a distance d the speed of the body is v .

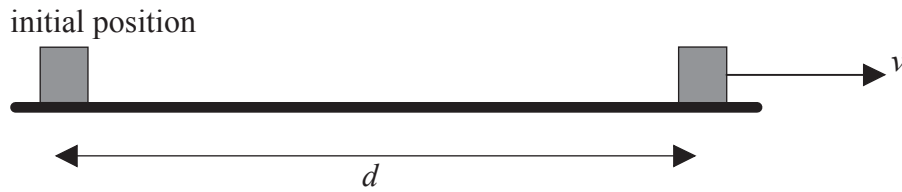

The speed of the body when it has travelled a distance $\frac{d}{2}$ from its initial position is

- A. $\frac{v}{4}$.
 - B. $\frac{v}{2}$.
 - C. $\frac{v}{\sqrt{2}}$.
 - D. $\frac{v}{2\sqrt{2}}$.
6. A toy cannon is mounted vertically on a cart. The cart is moving along a straight-line with constant speed. A spring inside the cannon shoots a ball vertically upwards.

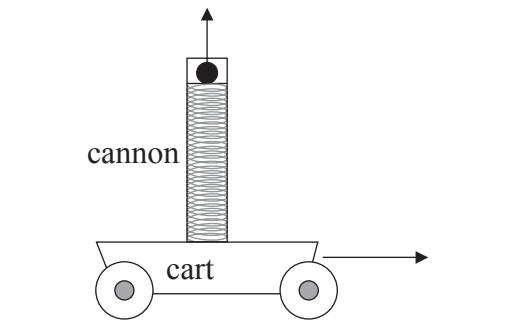

No resistance forces act on the cart and on the ball. Which **one** of the following statements is true about the position where the ball will land?

- A. The position depends on the speed of the cart.
- B. The ball will land behind the cannon.
- C. The ball will land inside the cannon.
- D. The ball will land in front of the cannon.

7. Mandy stands on a weighing scale inside a lift (elevator) that accelerates vertically upwards as shown in the diagram below. The forces on Mandy are her weight W and the reaction force from the scale R .

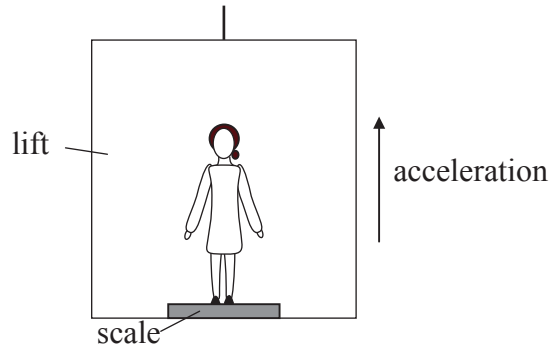

The reading of the scale is

- A. $R + W$.
- B. W .
- C. R .
- D. $R - W$.

8. A body of weight $2W$ hangs vertically from a string attached to a body of weight W . Weight W is released and both bodies fall vertically.

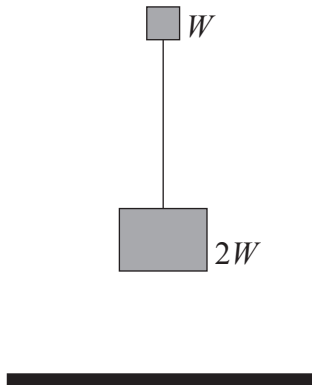

Air resistance may be neglected. What is the tension in the string during the fall?

- A. Zero
 - B. W
 - C. $2W$
 - D. $3W$
9. The graph below shows the variation with time t of the magnitude of the net force F acting on a body moving along a straight-line.

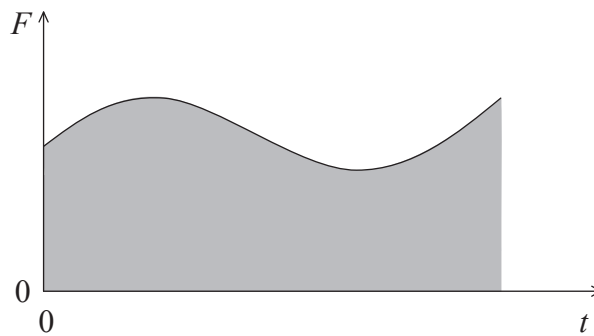

The shaded area represents

- A. the total work done by F .
- B. the change in the kinetic energy of the body.
- C. the change in the momentum of the body.
- D. the change in the velocity of the body.

10. A fan and a sail are mounted vertically on a cart that is initially at rest on a horizontal table as shown in the diagram below.

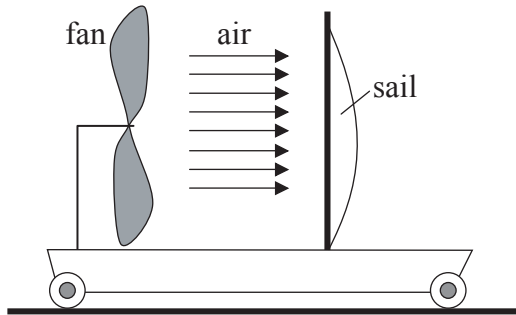

When the fan is turned on an air stream is blown towards the right and is incident on the sail. The cart is free to move with negligible resistance forces.

After the fan has been turned on the cart will

- A. move to the left and then to the right.
 - B. remain at rest.
 - C. move towards the right.
 - D. move towards the left.
11. A body moving along a straight-line has mass 3.0kg and kinetic energy 24J. The motion is then opposed by a net force of 4.0N. The body will come to rest after travelling a distance of
- A. 2.0m.
 - B. 6.0m.
 - C. 8.0m.
 - D. 12m.

12. A brick is placed on the surface of a flat horizontal disc as shown in the diagram below. The disc is rotating at constant speed about a vertical axis through its centre. The brick does not move relative to the disc.

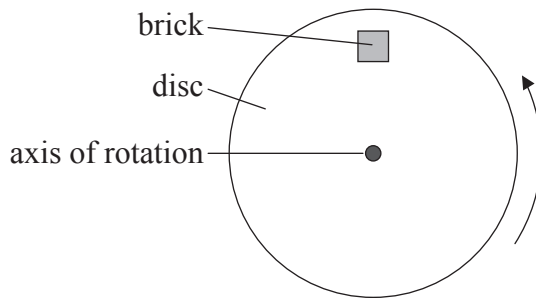

Which of the diagrams below correctly represents the **horizontal** force or forces acting on the brick?

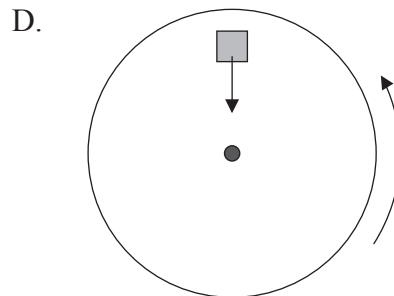
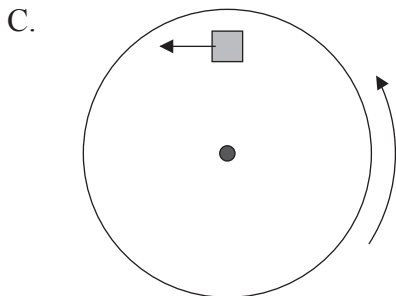
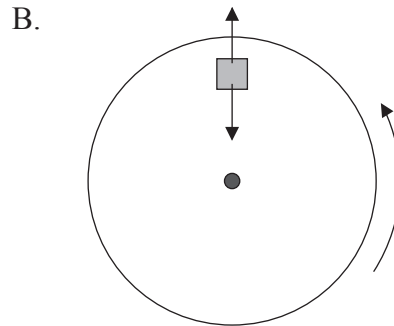
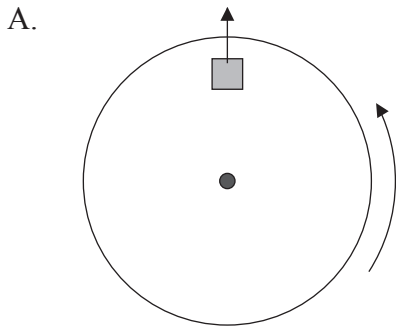

13. The heat capacity of a solid body is defined as
- A. the thermal energy required to increase the body's temperature by one degree.
 - B. the maximum thermal energy that must be supplied to melt the solid.
 - C. the total kinetic energy of the solid's molecules.
 - D. the average kinetic energy of the solid's molecules.

14. Which **one** of the following correctly describes the changes, if any, of the kinetic energy and the potential energy of the molecules of a liquid as it is boiling?

| | Kinetic energy | Potential energy |
|----|-----------------------|-------------------------|
| A. | increases | increases |
| B. | increases | stays constant |
| C. | stays constant | increases |
| D. | stays constant | stays constant |

15. A metal rod and a rubber rod are at the same temperature. When held in the hand, the metal rod “feels” colder than the rubber rod. The best explanation for this observation is that the metal

- A. has a lower specific heat capacity than rubber.
- B. has a higher melting point than rubber.
- C. is a better conductor of thermal energy than rubber.
- D. is a better absorber of thermal energy than rubber.

16. A fixed quantity of an ideal gas is compressed at constant temperature. The best explanation for the increase in pressure is that the molecules

- A. are moving faster.
- B. are colliding more frequently with the container walls.
- C. exert greater forces on each other.
- D. are colliding more frequently with each other.

17. A string is held horizontally with one end attached to a fixed support. Two pulses are created at the free end of the string. The pulses are moving towards the fixed support as shown in the diagram below.

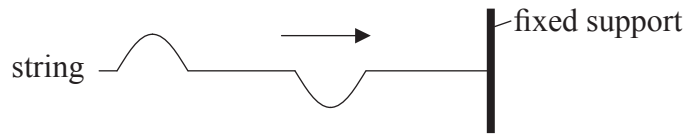

Which **one** of the following diagrams is a possible subsequent picture of the string?

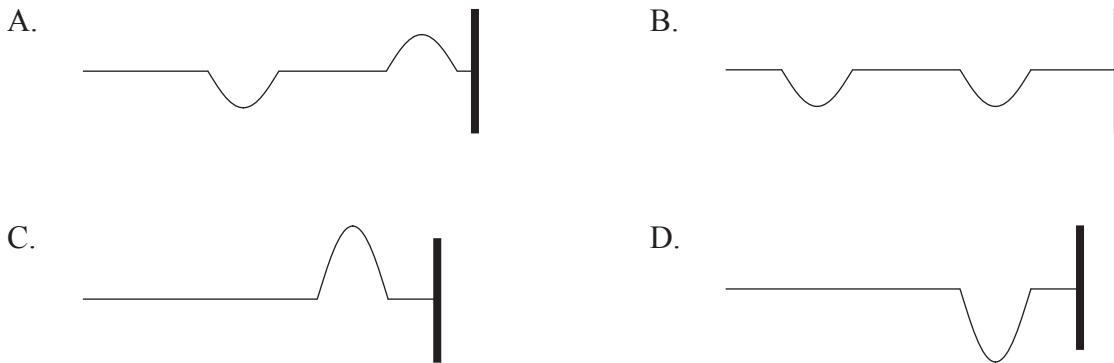

18. A water surface wave (ripple) is travelling to the right on the surface of a lake. The wave has period T . The diagram below shows the surface of the lake at a particular instant of time. A piece of cork is floating in the water in the position shown.

Which is the correct position of the cork a time $\frac{T}{4}$ later?

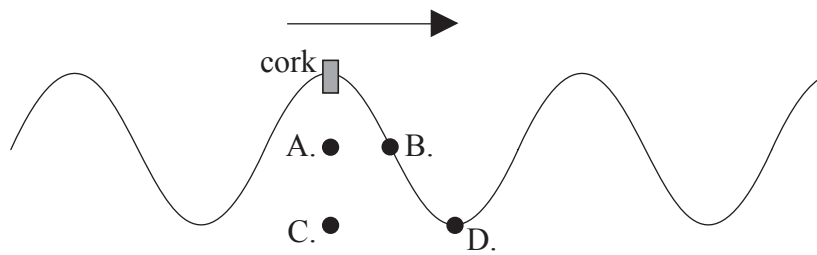

19. The diagram below shows a photograph of part of a **standing wave** on a string that is fixed at both ends. The wavelength of the wave is 40 cm. At a particular time the point marked P has displacement +2.0 cm and moves with velocity +80 m s⁻¹.

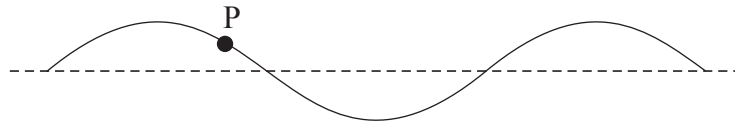

A second point Q on the string is at a distance of 20 cm from P. At the same time that the photograph above was taken, the displacement and velocity of point Q were

| | Displacement | Velocity |
|----|--------------|-----------------------|
| A. | +2.0 cm | +80 m s ⁻¹ |
| B. | +2.0 cm | -80 m s ⁻¹ |
| C. | -2.0 cm | +80 m s ⁻¹ |
| D. | -2.0 cm | -80 m s ⁻¹ |

20. A source of sound is placed near the open end of a cylindrical tube that lies on a horizontal table. The tube has some powder sprinkled along its length. The powder collects in piles along the length of the tube as shown below.

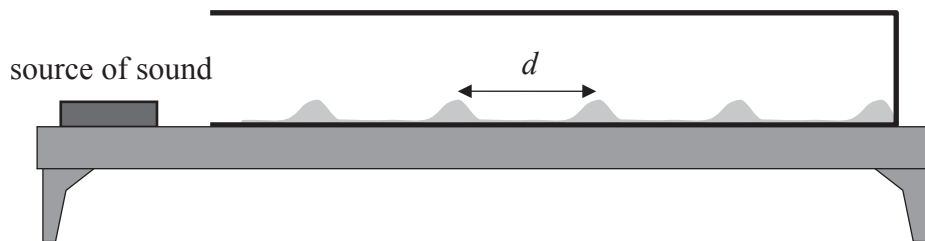

The distance between two consecutive piles of powder is d and the speed of sound in the tube is v . The frequency of the source is

- A. $\frac{v}{2d}$.
- B. $\frac{v}{d}$.
- C. dv .
- D. $2dv$.

21. The diagram below shows two long parallel plates that are oppositely charged. A positive test charge $+q$ is placed along the dotted line XY.

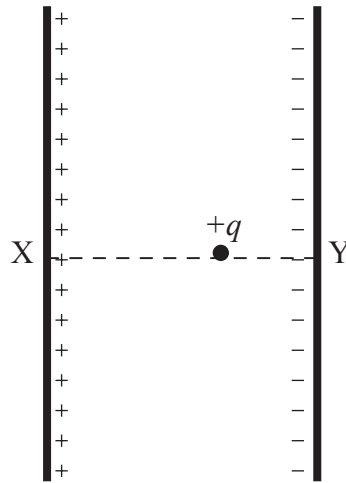

The charge $+q$ is moved from X to Y. Which **one** of the following best shows the variation with distance d from X of the magnitude F of the force on $+q$?

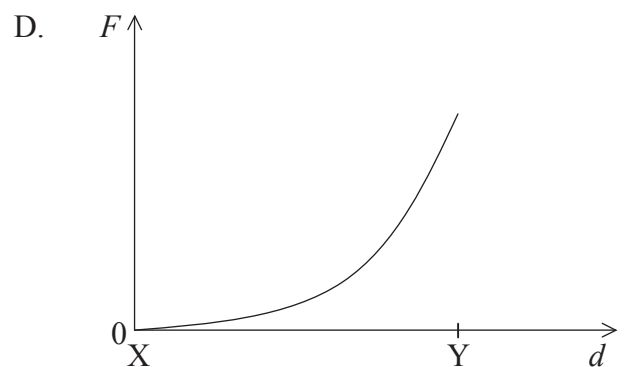
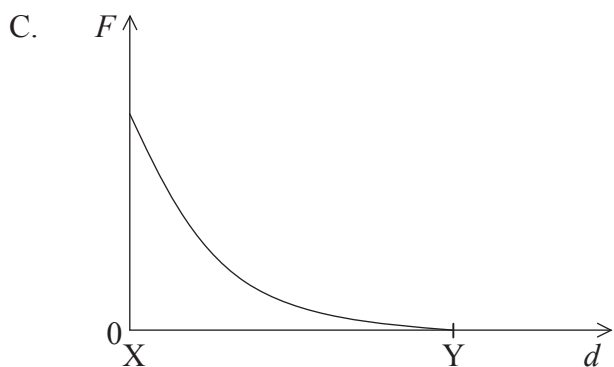
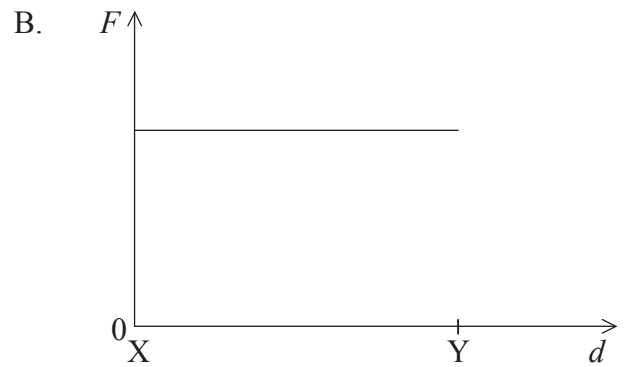
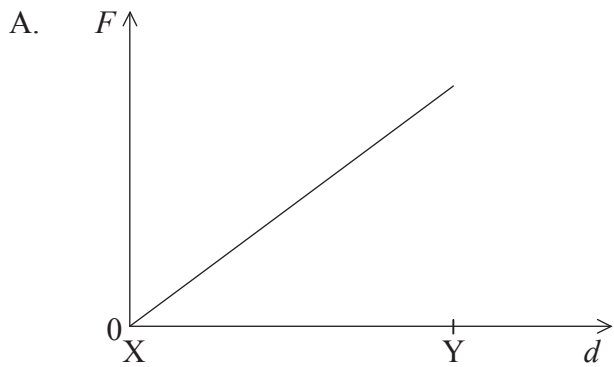

22. X and Y are two identical conducting spheres separated by a distance d . X has a charge $+6 \mu\text{C}$ and Y has a charge $-2 \mu\text{C}$. The electric force between them is $+F$ (*i.e.* attractive). The spheres are touched together and are then returned to their original separation d . The force between them now is

- A. $+F$.
- B. $-F$.
- C. $+\frac{F}{3}$.
- D. $-\frac{F}{3}$.

23. An electrically neutral conducting sphere is suspended vertically from an insulating thread.

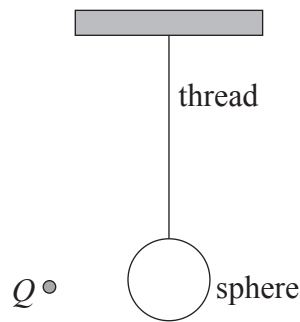

A point charge of magnitude Q is brought near the sphere. The electric force between the point charge and the sphere

- A. depends on whether Q is positive or negative.
- B. is always zero.
- C. is always repulsive.
- D. is always attractive.

24. In the circuit below, the battery has negligible internal resistance. Lamps L, M and N which have different resistance are connected as shown.

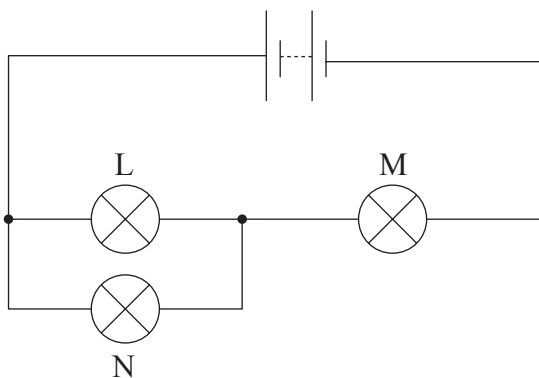

Which **one** of the following is always true?

- A. Lamps L and N have the same current through them.
- B. Lamps L and M have the same current through them.
- C. Lamps L and N have the same potential difference across them.
- D. Lamps L and M have the same potential difference across them.

25. In the circuit below the battery has e.m.f. 6.0 V and negligible internal resistance. The three resistors each have resistance $10\ \Omega$. A high resistance voltmeter is connected as shown.

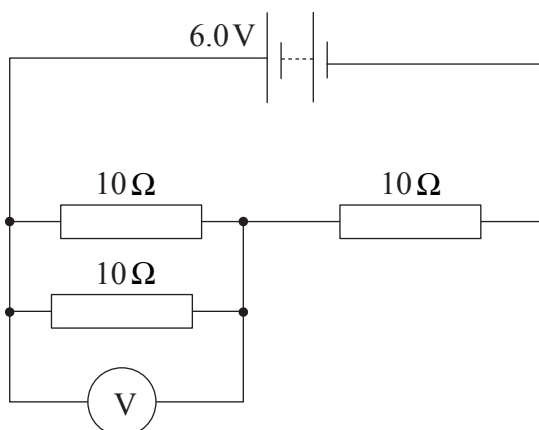

The reading of the voltmeter is

- A. 2.0 V .
 - B. 3.0 V .
 - C. 4.0 V .
 - D. 6.0 V .
26. A conductor of constant resistance dissipates 6.0 W of power when the potential difference across it is 12 V . The power that will be dissipated in this conductor when the potential difference across it is 24 V is
- A. 6.0 W .
 - B. 12 W .
 - C. 24 W .
 - D. 48 W .

27. Two long, parallel, straight wires X and Y carry equal currents into the plane of the page as shown. The diagram shows arrows representing the magnetic field strength B at the position of each wire and the magnetic force F on each wire.

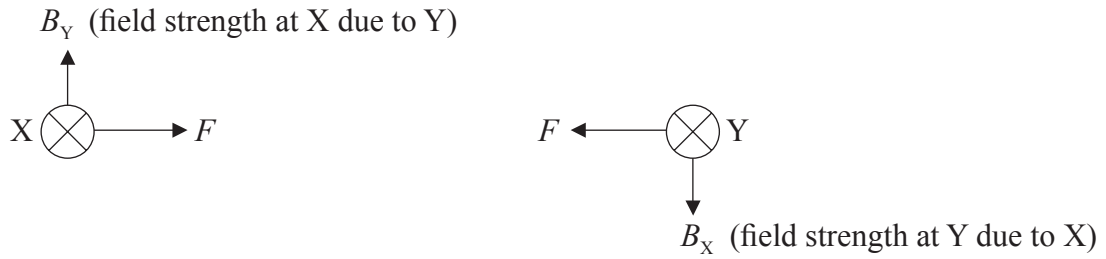

The current in wire Y is doubled. Which diagram best represents the magnetic field strengths and forces?

- A.
-
- X \leftarrow B_Y \rightarrow F $2F$ \leftarrow Y \rightarrow B_X \rightarrow F
- B.
-
- X \leftarrow B_Y \rightarrow $2F$ $2F$ \leftarrow Y \rightarrow B_X \rightarrow $2F$
- C.
-
- X \leftarrow $2B_Y$ \rightarrow $2F$ F \leftarrow Y \rightarrow $2B_X$ \rightarrow F
- D.
-
- X \leftarrow $2B_Y$ \rightarrow $2F$ $2F$ \leftarrow Y \rightarrow B_X \rightarrow $2F$

28. A sample of material contains $64 \mu\text{g}$ of a radioactive isotope. After sixty minutes $2.0 \mu\text{g}$ of the isotope remain. The half-life of this isotope is
- A. 10 minutes.
 - B. 12 minutes.
 - C. 15 minutes.
 - D. 20 minutes.
29. The process represented by ${}^3_2\text{He} + {}^3_2\text{He} \rightarrow {}^4_2\text{He} + 2{}^1_1\text{H}$ would be described as
- A. alpha decay.
 - B. nuclear fission.
 - C. nuclear fusion.
 - D. scattering of helium by helium.
30. The binding energy per nucleon of the nucleus ${}^7_3\text{Li}$ is approximately 5 MeV. The total energy required to completely separate the nucleons of this nucleus is approximately
- A. 15 MeV.
 - B. 20 MeV.
 - C. 35 MeV.
 - D. 50 MeV.
-