



PHYSICS
HIGHER LEVEL
PAPER 2

Tuesday 4 November 2008 (afternoon)

2 hours 15 minutes

Candidate session number

0	0							
---	---	--	--	--	--	--	--	--

INSTRUCTIONS TO CANDIDATES

- Write your session number in the boxes above.
- Do not open this examination paper until instructed to do so.
- Section A: answer all of Section A in the spaces provided.
- Section B: answer two questions from Section B in the spaces provided.
- At the end of the examination, indicate the numbers of the questions answered in the candidate box on your cover sheet.



SECTION A

Answer **all** the questions in the spaces provided.

A1. This question is about the mass-radius relation for a certain type of star.

The radius R and mass M of ten different stars were measured and the results are shown plotted below.

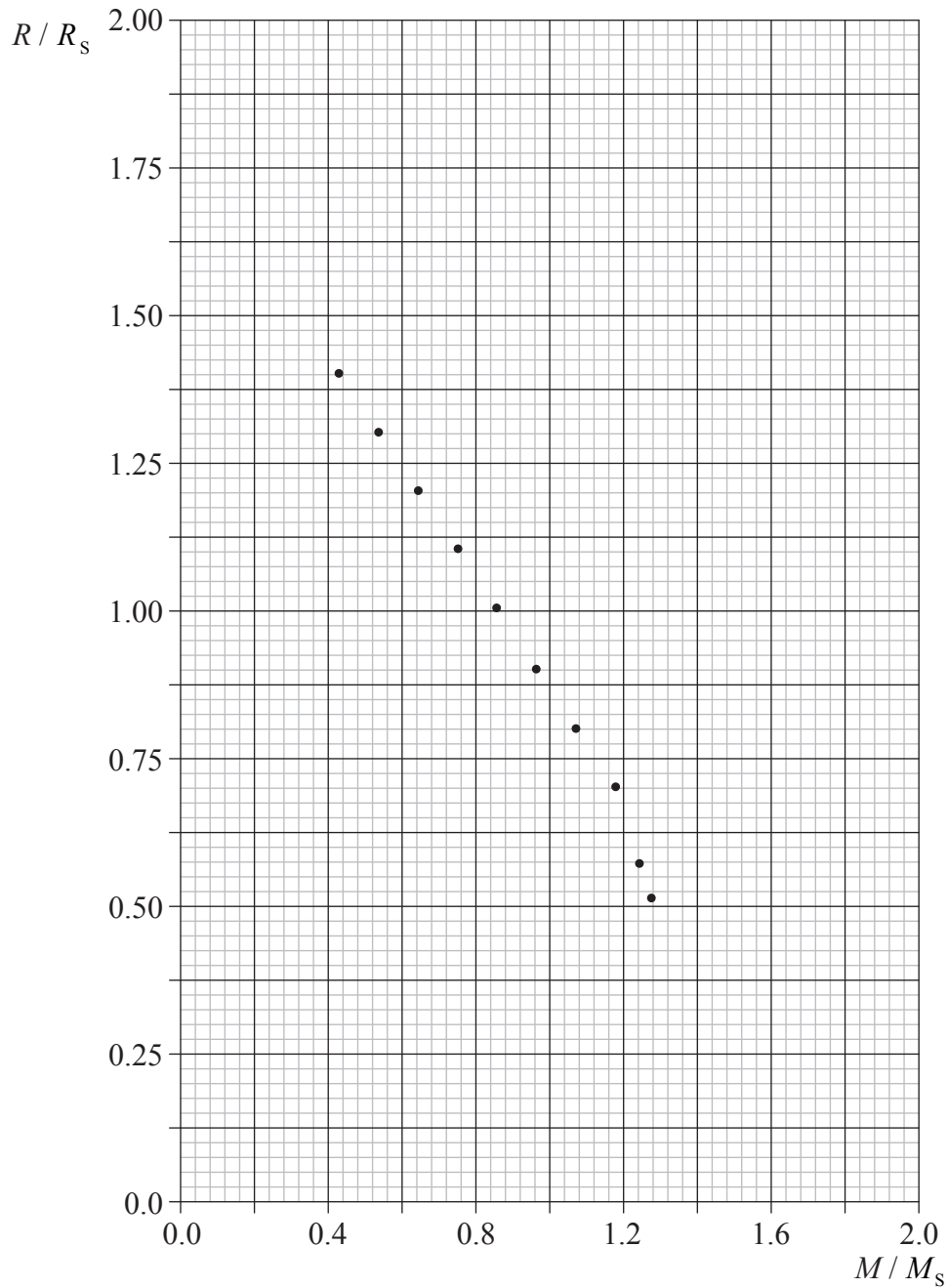

(This question continues on the following page)



(Question A1 continued)

The radius is expressed in terms of the Sun's radius R_s and the mass in terms of the Sun's mass M_s .

The uncertainty in the measurement of the mass is negligible. The uncertainty in the measurement of the radius is $\pm 0.05 R_s$.

(a) Draw error bars for the first and the last data points. [1]

(b) Using your answer to (a),

(i) suggest why there might be a linear relationship between R and M for these stars. [2]

.....
.....

(ii) determine the equation for this linear relationship. [3]

.....
.....
.....
.....
.....
.....
.....

(iii) estimate the maximum value for the mass of this type of star. [1]

.....
.....

(c) Suggest why no star of this type can in fact have a mass equal to your answer to (b)(iii). [1]

.....

(This question continues on the following page)



(Question A1 continued)

- (d) Additional data show that the relation between R and M is in fact not linear, as suggested by the graph below.

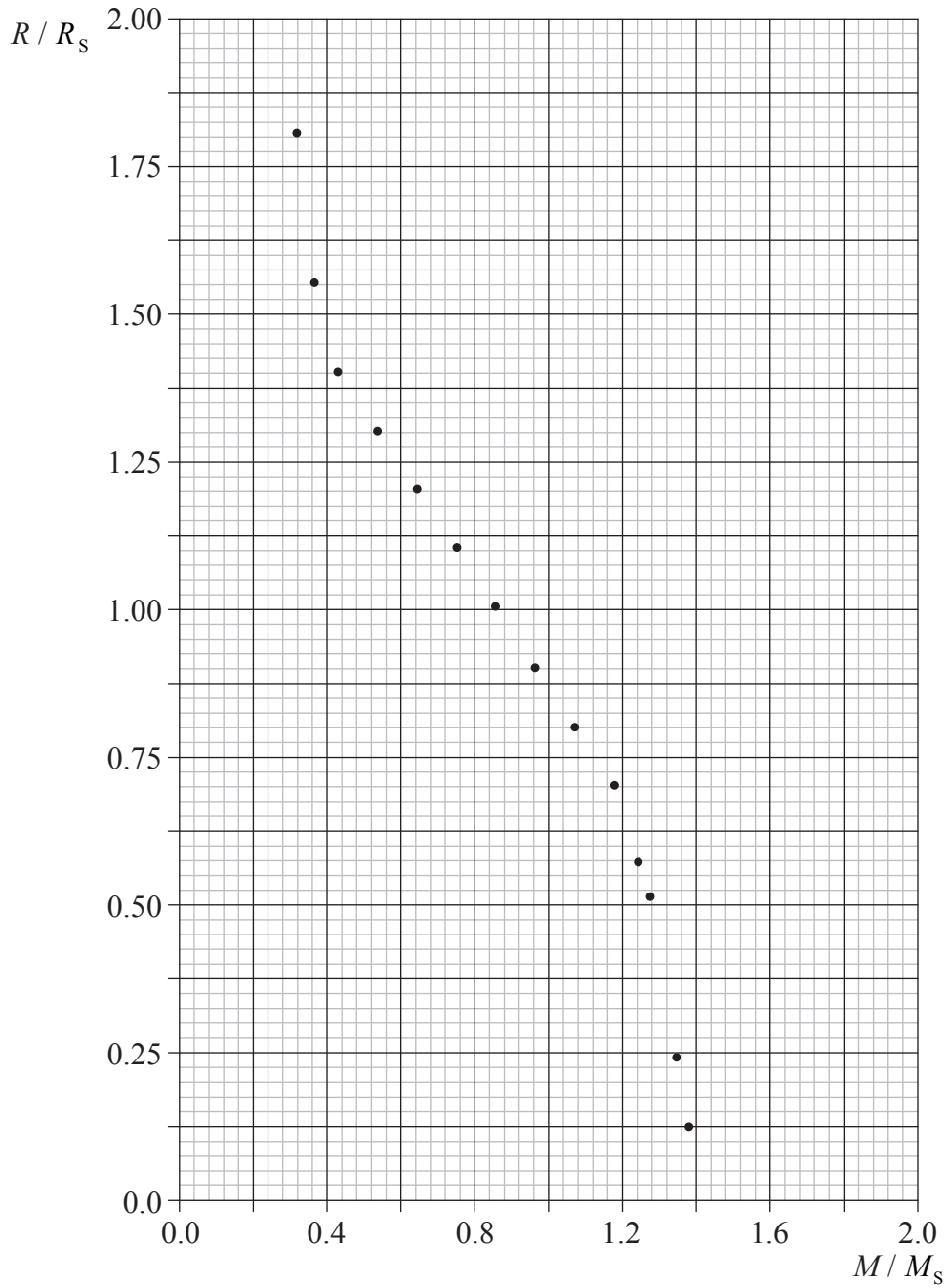

Uncertainties in the data are not shown.

(This question continues on the following page)



(Question A1 continued)

(i) Draw a line of best-fit for the data. [1]

(ii) The new data suggests that the maximum value for the mass of this type of star is different from your answer in (b)(iii). Estimate this new value. [1]

.....
.....

(iii) Suggest why your answer to (d)(ii) is only an estimate. [1]

.....

(e) It is hypothesized that the mass-radius relation for a different type of star is $R=kM^n$ where k and n are constants.

Explain how a graph may be used to

(i) verify this hypothesis. [2]

.....
.....
.....
.....

(ii) determine the constant n . [1]

.....
.....



A2. This question is about momentum.

- (a) A rocket in outer space far from any other masses is used to propel a satellite. At $t=0$ the engines are turned on and gases leave the rear of the rocket with speed v relative to the rocket.

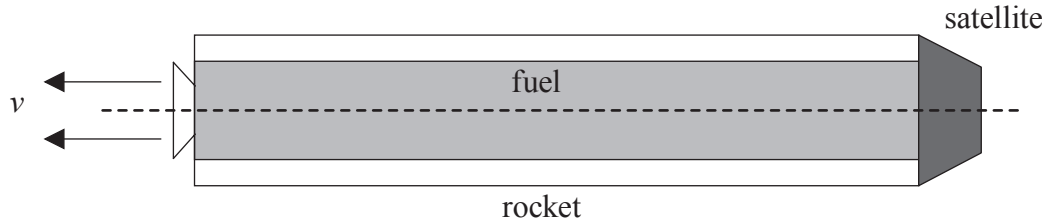

- (i) Explain, in terms of Newton's laws of motion, why the rocket will accelerate. [2]

.....

.....

.....

.....

- (ii) Outline how the law of conservation of momentum applies to the motion of the rocket. [2]

.....

.....

.....

- (iii) The gases leave the rear of the rocket at a constant rate of R kg per second. The mass of the rocket (including fuel) at $t=0$ is M .

Deduce that the initial acceleration, a , of the rocket is given by the expression

$$a = \frac{Rv}{M}. \quad [3]$$

.....

.....

.....

.....

.....

(This question continues on the following page)



(Question A2 continued)

- (b) The diagram below shows a two-stage rocket that is used to accelerate a satellite that has the same mass as in (a). The rocket has the same mass as the single stage rocket and carries the same mass of fuel as in (a).

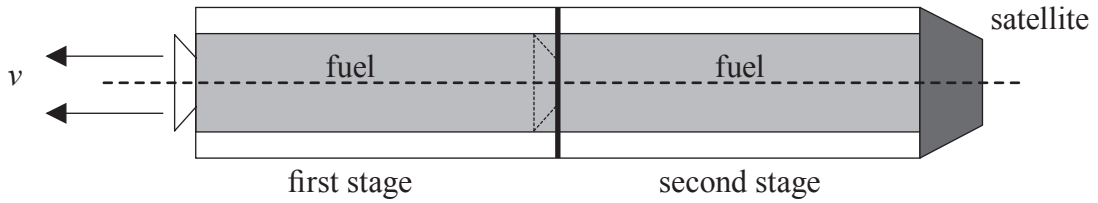

Each stage is discarded after all its fuel has been used. Explain, using the answer in (a)(iii), whether the final speed of the satellite will be larger, equal **or** smaller than that of the satellite accelerated by the single stage rocket. [2]

.....

.....

.....

.....



A3. This question is about ideal gases.

(a) State what is meant by an ideal gas. [1]

.....
.....

(b) For an ideal gas

(i) define *internal energy*. [1]

.....
.....

(ii) state and explain how the internal energy and the absolute (kelvin) temperature are related. [2]

.....
.....
.....

(This question continues on the following page)



(Question A3 continued)

(c) Point A in the p - V diagram below represents the state of an ideal gas.

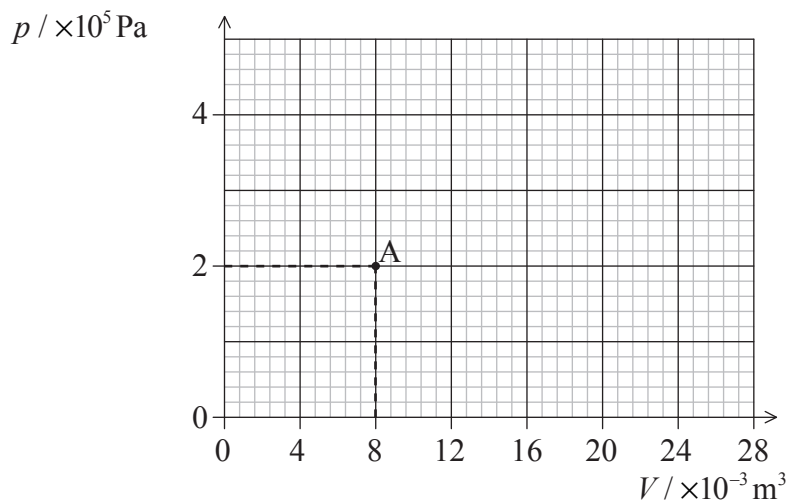

The number of moles of the gas is 0.64.

(i) Deduce that the temperature of the gas in state A is approximately 300 K. [1]

.....
.....
.....

(ii) A quantity Q of thermal energy is supplied to the gas at constant pressure. The temperature of the gas increases to 900 K. Calculate the new volume of the gas. [2]

.....
.....

(iii) Determine the work done by the gas in this change of state. [2]

.....
.....

(iv) State and explain, using the first law of thermodynamics, whether the final temperature of the gas would be equal to, less than **or** greater than 900 K if Q had been absorbed at constant volume. [3]

.....
.....
.....
.....



SECTION B

This section consists of four questions: B1, B2, B3 and B4. Answer **two** questions.

B1. This question is in **two** parts. **Part 1** is about wave motion. **Part 2** is about electromagnetic induction.

Part 1 Wave motion

(a) A wave is travelling on a string in the x direction. The two graphs show the variation with distance x of the displacement y of the string. Graph 1 corresponds to time $t=0$ and graph 2 to time $t=0.20$ s.

Graph 1 ($t=0$)

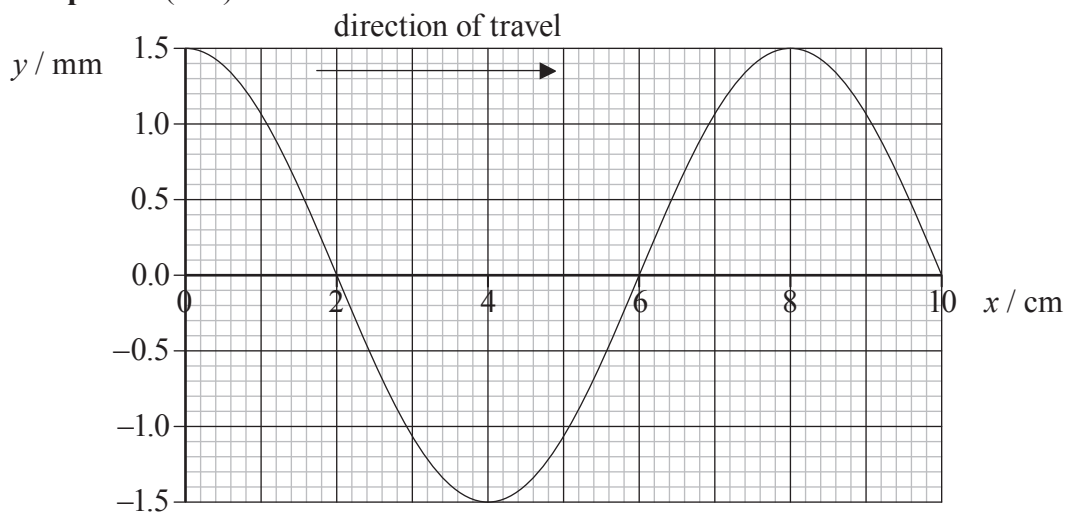

Graph 2 ($t=0.20$ s)

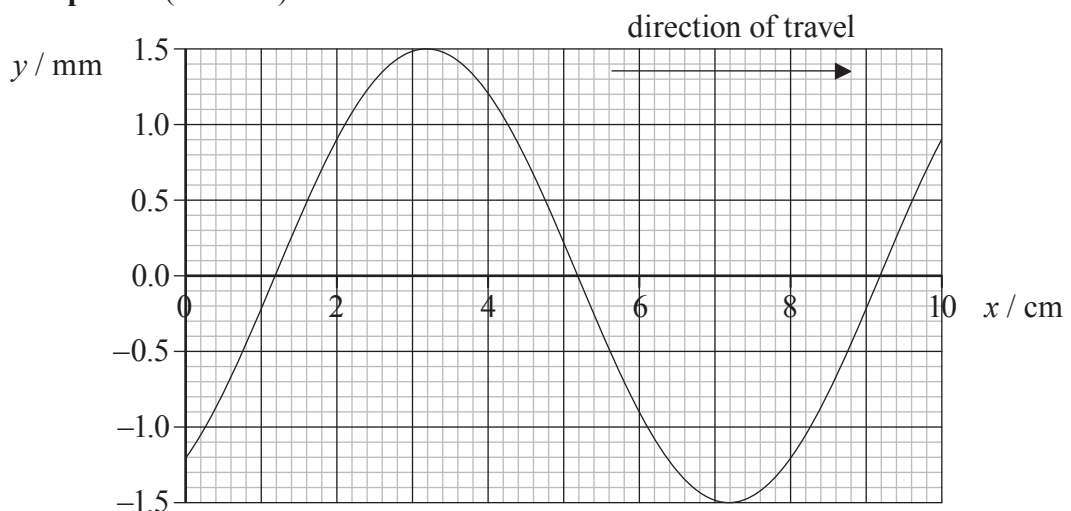

(This question continues on the following page)



(Question B1, part 1 continued)

The period of the wave is longer than 0.20 s.

Use the graphs to determine, for this wave,

(i) the amplitude. [1]

.....

(ii) the wavelength. [1]

.....

(iii) the speed. [2]

.....
.....
.....

(iv) the frequency. [1]

.....

(b) State **two** differences between a travelling wave and a standing wave. [2]

.....
.....
.....
.....

(c) Explain what is meant by wave speed with reference to

(i) travelling waves. [1]

.....
.....

(ii) standing waves. [2]

.....
.....

(This question continues on the following page)



(Question B1, part 1 continued)

- (d) The ends of a string are kept fixed and a standing wave is established on the string as represented in the diagram below.

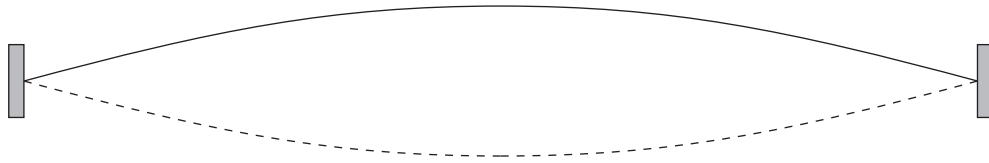

The standing wave causes a sound wave.

- (i) Explain how the standing wave creates a sound wave. [2]

.....
.....
.....

- (ii) The speed of sound in air is 340 m s^{-1} . The length of the string is 0.80 m and the speed of the wave on the string is 240 m s^{-1} .

Calculate the wavelength of the sound in air. [3]

.....
.....
.....
.....

(This question continues on the following page)



(Question B1 continued)

Part 2 Electromagnetic induction

(a) State Faraday's law of electromagnetic induction. *[1]*

.....
.....

(This question continues on the following page)



(Question B1, part 2 continued)

- (b) A length of conducting wire is formed into a square loop. The length of each side of the loop is L . In the diagram below the loop is sliding on a horizontal frictionless table and is about to enter a region of uniform magnetic field.

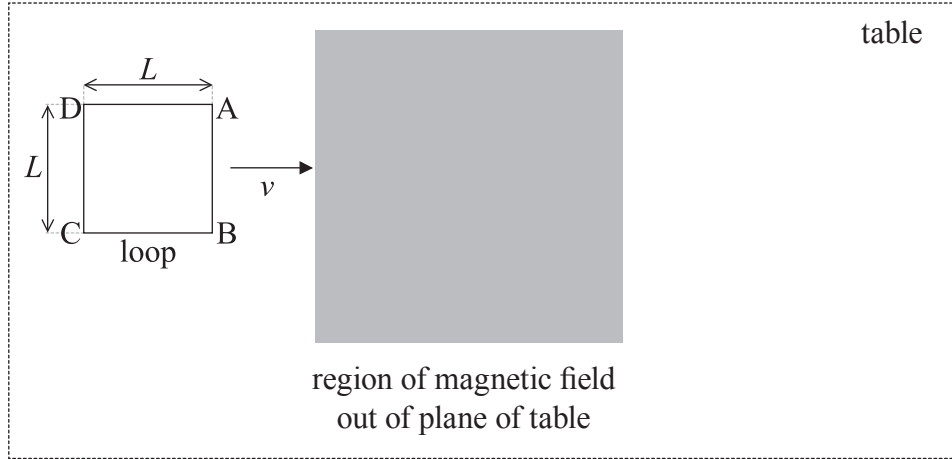

The magnitude of the magnetic field strength is B . The magnetic field is directed out of the plane of the table.

The side AB of the loop enters the region of magnetic field at $t=0$. The variation with time t of the speed v of the loop is shown in the graph below.

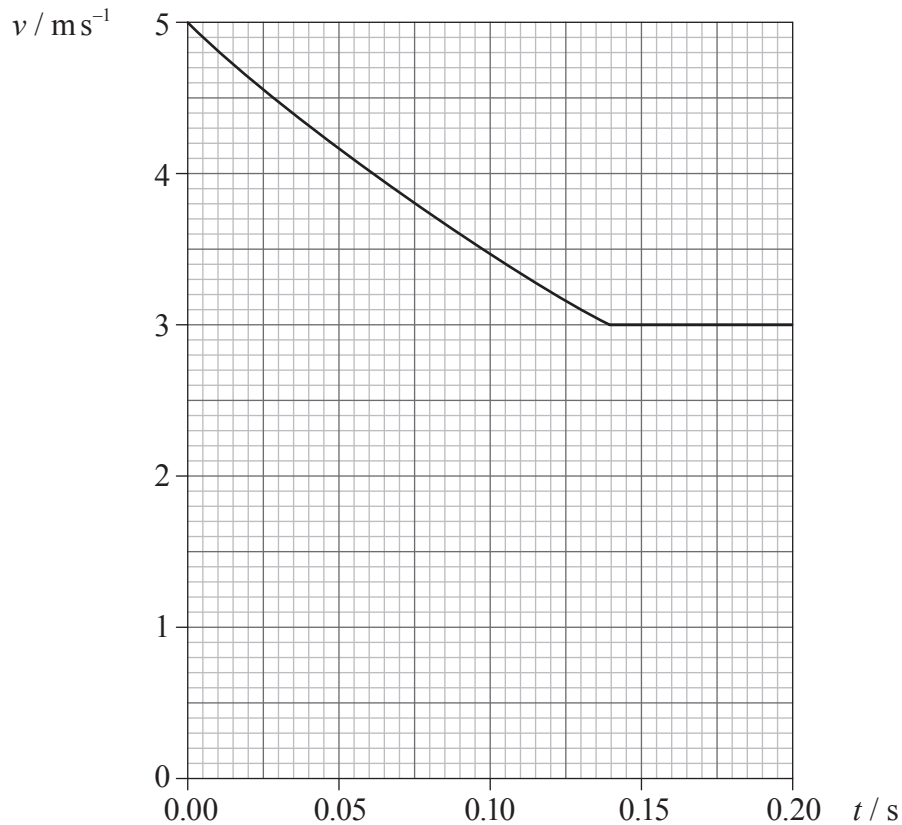

(This question continues on the following page)



(Question B1, part 2 continued)

- (i) Explain, with reference to the laws of electromagnetic induction, why the speed of the loop is decreasing. [3]

.....

.....

.....

.....

.....

- (ii) Deduce that while the loop is entering the region of magnetic field the induced e.m.f. V in the loop is given by the expression [2]

$$V = BLv.$$

.....

.....

.....

.....

- (iii) The side of the loop is $L = 0.54\text{ m}$ and the magnitude of the magnetic field is $B = 0.30\text{ T}$. Calculate the induced e.m.f. in the loop at $t = 0$ and at $t = 0.18\text{ s}$. [3]

$t = 0:$

.....

$t = 0.18\text{ s}:$

.....

- (c) The mass of the loop is 0.060 kg and its resistance is $0.12\ \Omega$. Calculate, using data from the graph in (b), the
 - (i) average power dissipated. [2]

.....

.....

.....

- (ii) maximum value of the current in the loop. [2]

.....

.....

.....

(This question continues on the following page)



(Question B1, part 2 continued)

- (d) On the axes below draw a sketch graph to show the variation with time t of the velocity v of the loop until it is completely outside the region of magnetic field. (This is a sketch graph you do not need to add values to the axes.) [2]

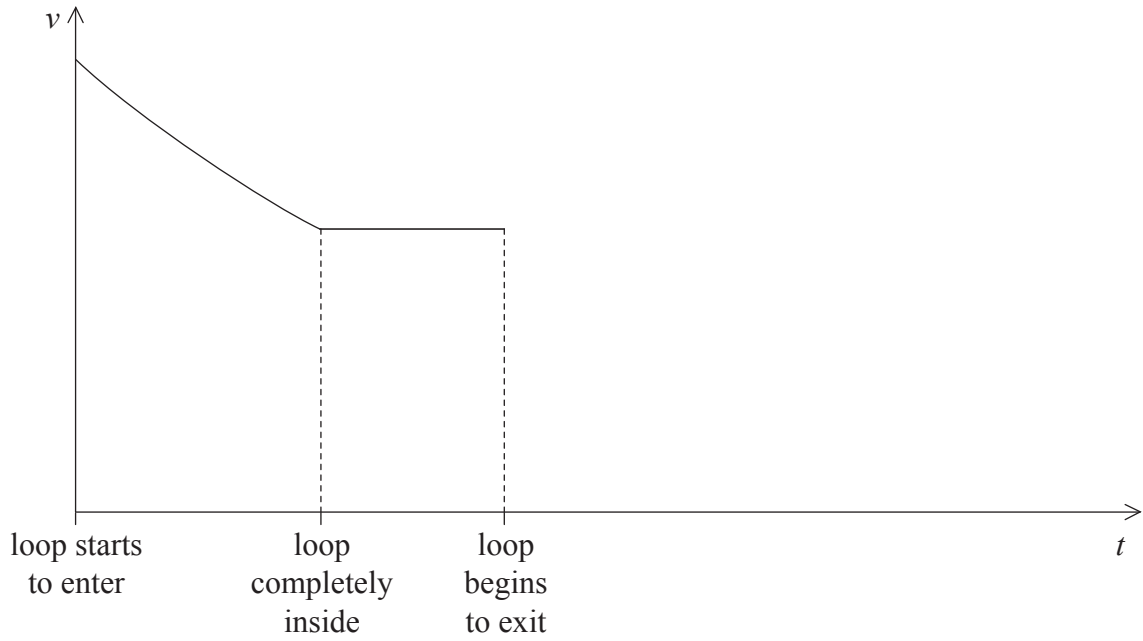

B2. This question is in **two** parts. **Part 1** is about nuclear fusion. **Part 2** is about the Doppler effect.

Part 1 Nuclear fusion

(a) Define *binding energy* of a nucleus. [1]

.....
.....

(b) Deduce, using the data below, that the binding energy per nucleon of the nucleus of tritium (${}^3_1\text{H}$) is 2.66 MeV. [3]

mass of tritium nucleus	3.016049 u
mass of proton	1.007276 u
mass of neutron	1.008665 u

.....
.....

(c) Using the data below, calculate in MeV the energy released in the reaction

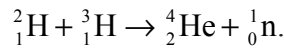

binding energy per nucleon, deuterium	${}^2_1\text{H}$	1.11 MeV	
binding energy per nucleon, tritium	${}^3_1\text{H}$	2.66 MeV	
binding energy per nucleon, helium	${}^4_2\text{H}$	7.20 MeV	[3]

.....
.....

(This question continues on the following page)



(Question B2, part 1 continued)

- (d) The diagram below shows a nucleus of deuterium (${}^2_1\text{H}$) and a nucleus of tritium (${}^3_1\text{H}$) that are approaching each other along a line joining their centres.



The kinetic energy of each nucleus is E_K . The distance of closest approach is d .

- (i) State the name of the force that prevents them from colliding. [1]

.....

- (ii) At the distance of closest approach the kinetic energy of both nuclei is negligible. Deduce that the distance d is given by the expression

$$d = \frac{kq_Dq_T}{2E_K}$$

where q_D is the charge of the deuterium nucleus, q_T is the charge of the tritium nucleus and k is the constant in Coulomb's law. [3]

.....

- (iii) Nuclear fusion of deuterium and tritium takes place when the nuclei are separated by a distance $d = 1.2 \times 10^{-14}$ m or less.

Deduce that the kinetic energy E_K corresponding to a distance $d = 1.2 \times 10^{-14}$ m is equal to 9.6×10^{-15} J. [2]

.....

(This question continues on the following page)



(Question B2, part 1 continued)

- (e) The average kinetic energy E , in joule, of nuclei is related to the absolute (kelvin) temperature T by

$$E = 2.1 \times 10^{-23} T.$$

- (i) Determine the temperature for which the average kinetic energy of the nuclei is 9.6×10^{-15} J. [1]

.....
.....

- (ii) Nuclear fusion of deuterium and tritium occurs at temperatures that are less than the temperature calculated in (e)(i). Suggest a reason for this. [2]

.....
.....

- (iii) Explain the need for high temperatures for nuclear fusion to occur. [2]

.....
.....
.....

- (iv) Suggest why, for large separations of the nuclei, the force between the nuclei is repulsive whilst for very small separations the force is attractive. [2]

.....
.....

(This question continues on the following page)



(Question B2 continued)

Part 2 The Doppler effect

- (a) State what is meant by the Doppler effect. [2]

.....

.....

.....

- (b) The frequency of a sound emitted by a source is f and its wavelength is λ . The speed of sound in air is v .

An observer is moving at constant speed u towards a stationary sound source.

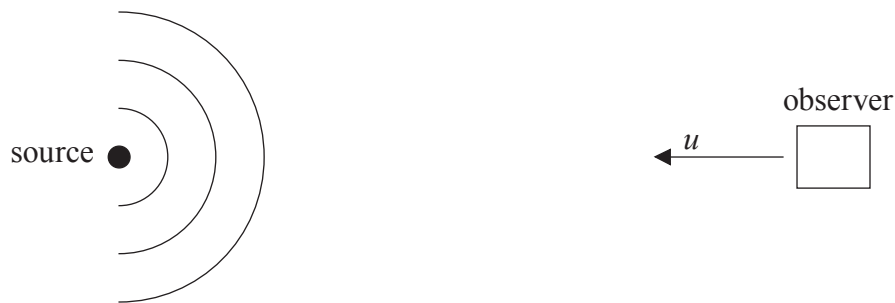

State, in terms of f , u and v , the

- (i) speed of the sound relative to the observer. [1]

.....

- (ii) frequency of the sound as measured by the observer. [1]

.....

- (c) Deduce that the wavelength of the sound as measured by the observer is equal to λ . [2]

.....

.....

.....

.....

(This question continues on the following page)



(Question B2, part 2 continued)

- (d) The frequency of the source is 1200 Hz. The sound is reflected from the moving observer and is received back at the source. The frequency of the received sound back at the source is 1400 Hz. The speed of sound v in air is 340 m s^{-1} .

Determine the speed u of the moving observer.

[4]

.....
.....
.....
.....
.....
.....



B3. This question is in **two** parts. **Part 1** is about mechanics. **Part 2** is about wave-particle duality.

Part 1 Mechanics

(a) A girl falls from rest on to the horizontal surface of a trampoline.

The graph below shows the variation with time t of the net force F exerted on the girl before, during and after contact with the trampoline.

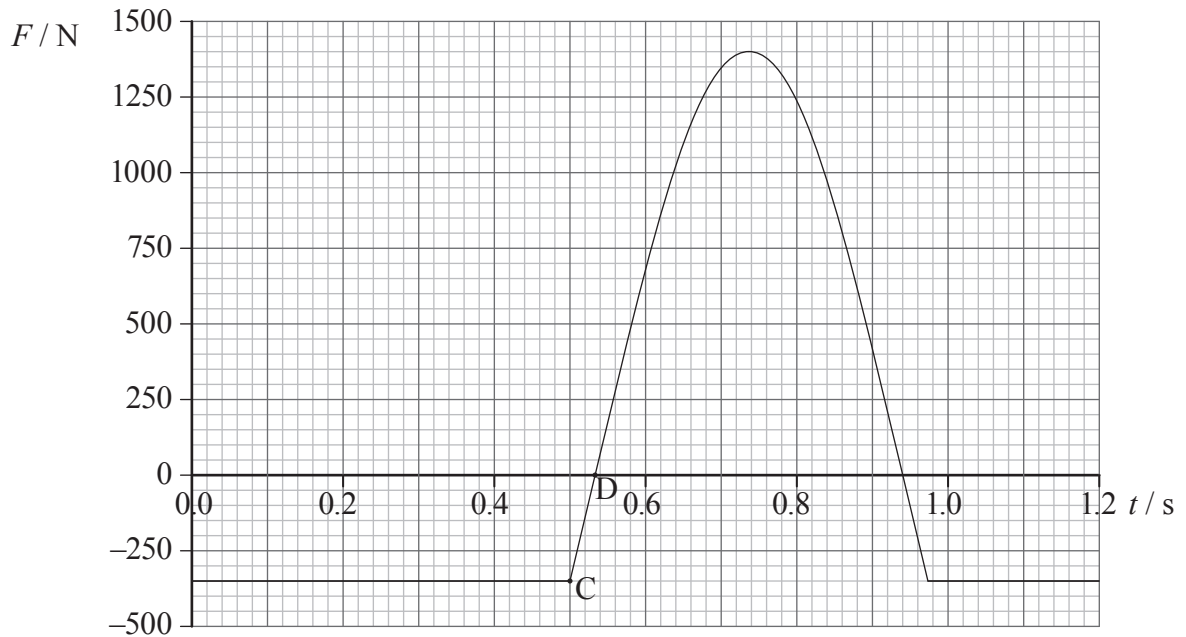

The girl first makes contact with the trampoline at point C.

Use data from the graph to calculate the

(i) mass of the girl. [1]

.....
.....

(ii) speed of the girl just before she lands on the trampoline. [2]

.....
.....
.....

(This question continues on the following page)



(Question B3, part 1 continued)

- (iii) initial height above the surface of the trampoline from which the girl falls. [2]

.....

.....

.....

- (iv) magnitude of the maximum acceleration of the girl for the time she is in contact with the trampoline. [2]

.....

.....

.....

(b) The girl has a maximum speed at point D as shown on the graph.

For the time between point C and point D

- (i) explain why the speed of the girl is increasing. [2]

.....

.....

.....

- (ii) deduce that the change in momentum of the girl is approximately 5 N s. [2]

.....

.....

.....

- (iii) estimate the maximum speed of the girl. [2]

.....

.....

.....

(This question continues on the following page)

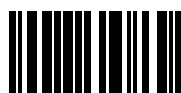

(Question B3 continued)

Part 2 Wave-particle duality

- (a) State the de Broglie hypothesis. [2]

.....

- (b) A tennis ball of mass 0.06 kg is thrown with speed 20 ms⁻¹ through a gap of width 1 m.

Discuss, with an appropriate calculation, whether the tennis ball will exhibit noticeable wavelike properties in this situation. [3]

.....

- (c) An electron is accelerated from rest through a potential difference V . Deduce that the de Broglie wavelength λ of the accelerated electron is given by

$$\lambda = \frac{h}{\sqrt{2meV}}$$

where m is the mass of the electron and e its electric charge. [3]

.....

- (d) Calculate the de Broglie wavelength of an electron that has been accelerated from rest through a potential difference of 54 V. [1]

.....

(This question continues on the following page)



(Question B3, part 2 continued)

- (e) In an experiment to verify the de Broglie hypothesis electrons that have been accelerated from rest through a potential difference of 54 V are incident on a single crystal of nickel. The diagram shows electrons incident on and reflected from two atoms of the crystal.

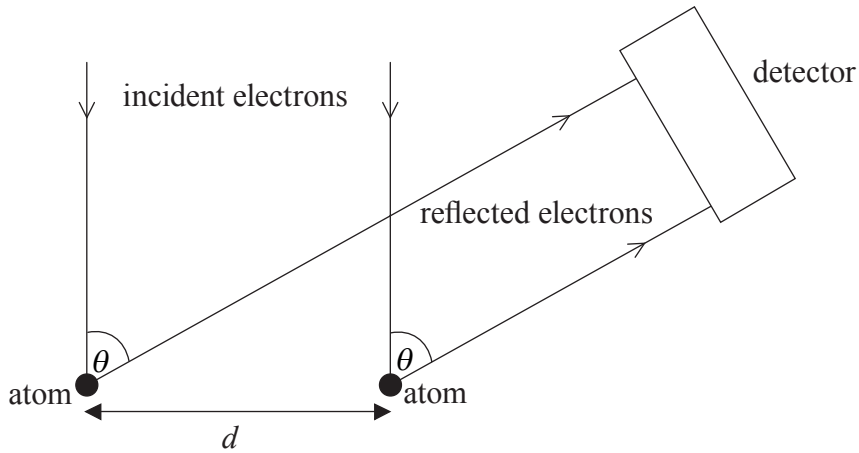

The atoms are separated by a distance d . The reflected electrons make an angle θ with the incident electron direction.

- (i) Draw a line on the diagram above to indicate the path difference between the reflected electrons. [1]
- (ii) Explain why the reading of the detector will be a maximum when the condition $d \sin \theta = \lambda$ is satisfied. [2]

.....
.....

- (f) The separation d is 2.15×10^{-10} m. A maximum in the intensity of the reflected electrons is observed at $\theta = 51^\circ$.

Explain, by reference to your answer to (d), how these values are consistent with the de Broglie hypothesis. [3]

.....
.....
.....

- (g) State **two** properties of a crystal that enable electron diffraction to be observed. [2]

.....
.....



B4. This question is in **two** parts. **Part 1** is about gravitation. **Part 2** is about electricity.

Part 1 Gravitation

Two stars of equal mass are in circular orbit about a common centre.

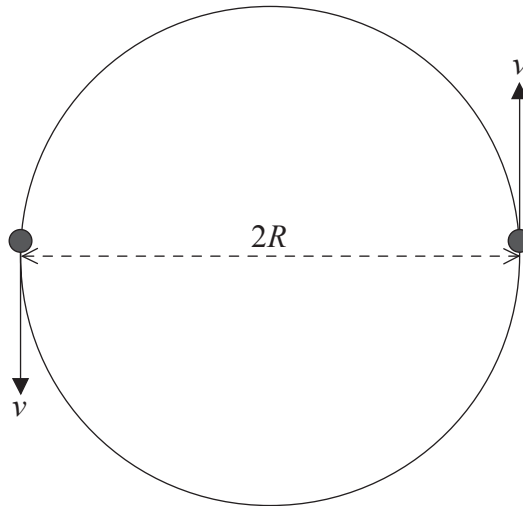

The mass of each star is M and their separation is $2R$. The speed of each star is v .

(a) Deduce that

(i) v is given by the expression

$$v = \sqrt{\frac{GM}{4R}}. \quad [2]$$

.....

(ii) the period of revolution T of each star is given by the expression

$$T = \sqrt{\frac{16\pi^2 R^3}{GM}}. \quad [2]$$

.....

(This question continues on the following page)



(Question B4, part 1 continued)

- (b) For a particular star system $R=6.5 \times 10^5$ km and $M=3.0 \times 10^{30}$ kg. Calculate the period of this system. [2]

.....

.....

.....

- (c) The total energy E of the star system is given by the expression $E = -\frac{GM^2}{4R}$. The system loses energy over time.

- (i) Explain how the loss of energy implies that the orbital period will decrease. [2]

.....

.....

.....

- (ii) The rate of decrease of the period of the star system in (b) is 7×10^{-5} s per year. Estimate the time, in years, when the stars will crash into each other, *i.e.* when the orbital period will become zero. [2]

.....

.....

(This question continues on the following page)



(Question B4 continued)

Part 2 Electricity

Static electricity

- (a) A positively charged particle hangs from a vertical insulating string. The particle is brought above an electrically neutral metallic sphere that rests on an insulating support.

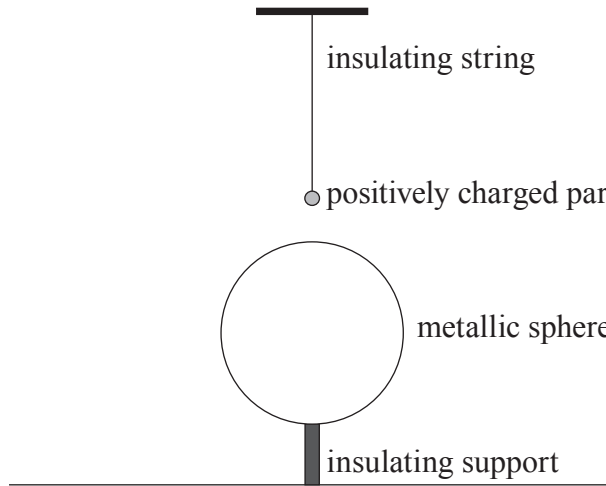

By considering the distribution of charge on the sphere, state and explain whether the tension in the string holding the charged particle will be less than, equal to **or** greater than the weight of the particle. (Assume that the mass of the string is negligible.) [3]

.....

.....

.....

.....

(This question continues on the following page)

(Question B4, part 2 continued)

(b) Diagrams A, B and C show a sequence of events in which:

- A: the sphere in (a) is earthed (grounded),
- B: the earth is then removed while the charged particle remains in place,
- C: finally the charged particle is taken away.

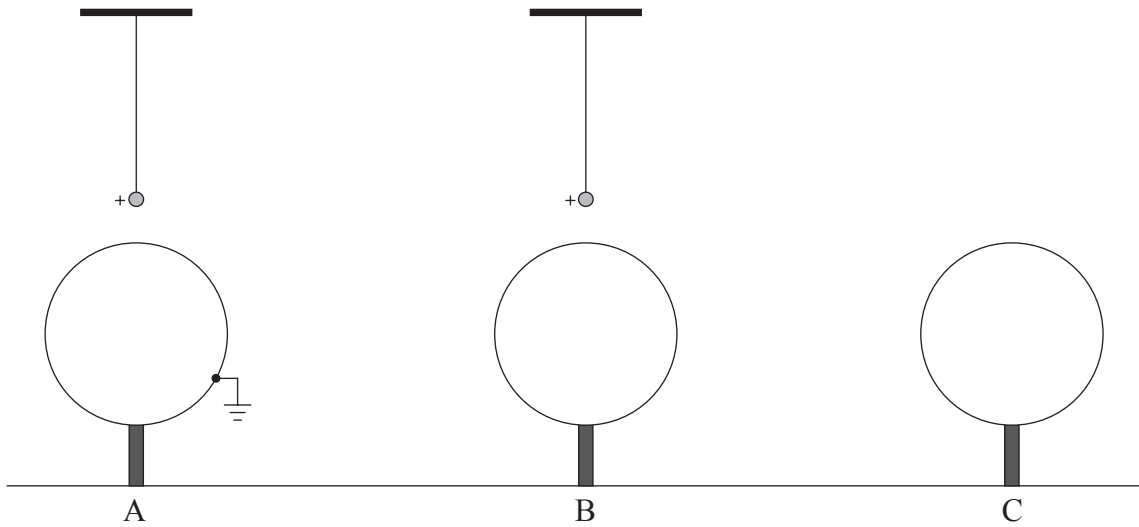

- (i) On each of the diagrams A, B and C draw the distribution of charge on the sphere. [3]
- (ii) Explain why work has to be done on the charged particle to move it away from the sphere. [2]

.....
.....

(This question continues on the following page)

(Question B4, part 2 continued)

Current electricity

- (c) Define *electromotive force* (e.m.f.). [1]

.....
.....

- (d) In the circuit below the battery has an e.m.f. of 12 V and an internal resistance of 5.0 Ω.

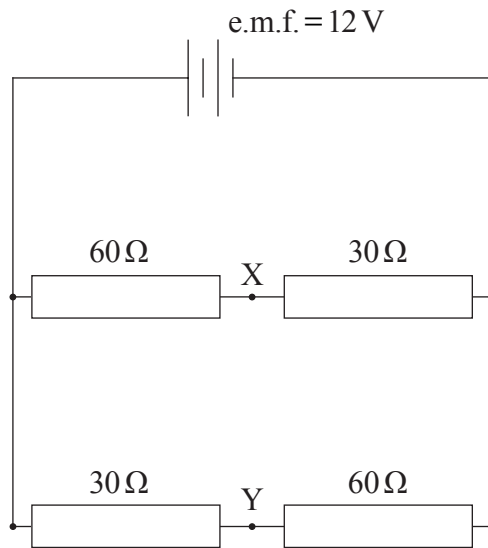

Calculate the

- (i) total resistance of the circuit. [3]

.....
.....
.....
.....

- (ii) current in the internal resistance. [1]

.....
.....

(This question continues on the following page)



(Question B4, part 2 continued)

(iii) total power dissipated in the circuit. [2]

.....
.....

(iv) potential difference between points X and Y. [3]

.....
.....
.....

(e) A real (*i.e.* non-ideal) voltmeter is connected across points X and Y in the circuit in (d). Explain why the reading of this voltmeter will not be the same as your answer to (d)(iv). [2]

.....
.....



H2. This question is about the reflection and refraction of laser light.

(a) Define *refractive index*.

[1]

.....
.....

(b) A beam of laser light is incident on a glass/air boundary.



(i) On the diagram above, draw rays to show the reflected ray (label this L) and the refracted ray (label this R).

[1]

(ii) The angle of incidence of the beam is gradually increased. Deduce how the path of the laser light would change for angles of incidence up to 80°. The refractive index of the glass is 1.5.

[4]

.....
.....
.....
.....
.....
.....

(This option continues on page 26)



H4. This question is about double slit and multiple slit diffraction.

In a Young's double slit type experiment, laser light of wavelength 650 nm is shone onto two slits. The resulting fringe pattern on a screen placed beyond the slits is shown below. The separation of the slits is 1.4×10^{-4} m.

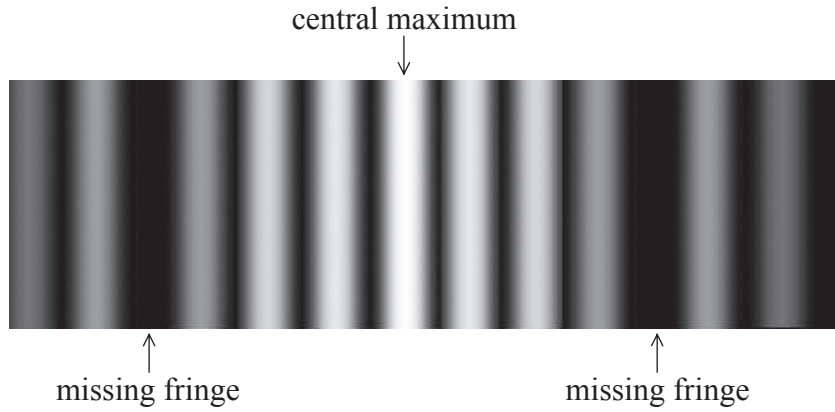

(a) (i) Explain the reason for the missing fringes. [2]

.....
.....
.....

(ii) Calculate the width of each slit. [2]

.....
.....
.....

(b) The double slit is replaced with a very large number of slits. Each of the slits is of a smaller width than those of the double slit but their separation is the same as in (a). Describe and explain any changes in the appearance of the fringe pattern as shown in (a). [3]

.....
.....
.....
.....